

CABINET TOP REMOVAL

Remove Phillips screws 1, 2 and 3 from the cabinet bottom. Carefully lift the cabinet top up and back. The keyboard is attached to the cabinet top. Unplug the keyboard and LED power plugs and remove cabinet top. See Figure 1.

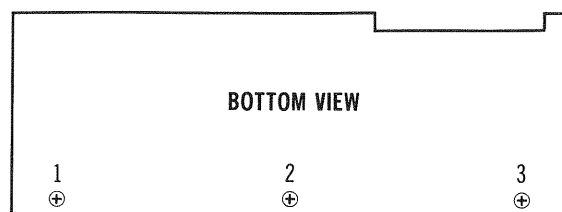

Figure 1

MAIN BOARD REMOVAL

Remove Phillips screws 1 thru 7 and lift the Main Board out of the cabinet bottom. To remove the shield, remove Phillips screws 8, 9 and 10 and unsolder the shield at points A thru G. See Figure 2.

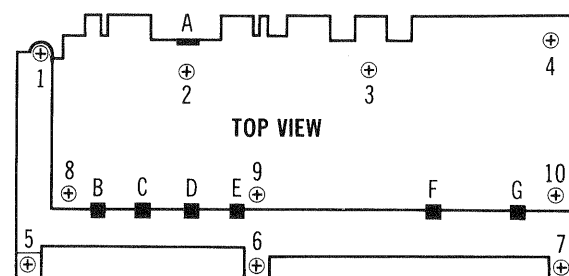

Figure 2

KEYBOARD REMOVAL

To remove the keyboard from the cabinet top, remove Phillips screws 1 thru 8 and lift the keyboard out of the cabinet. See Figure 3.

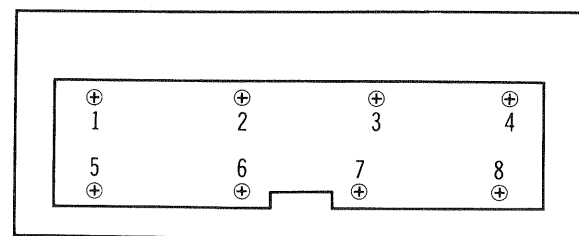
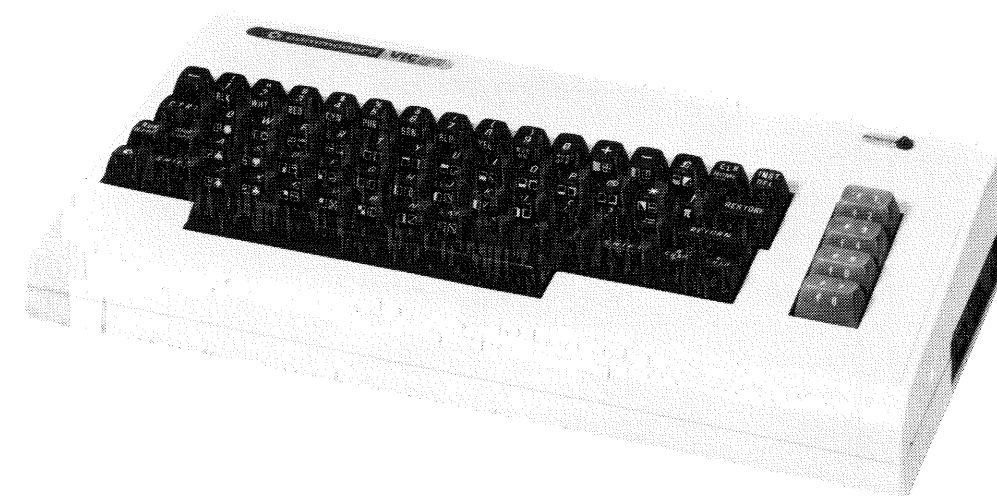

Figure 3

COMMODORE
MODEL VIC 20
CC3



CC3
COMMODORE
MODEL VIC 20

PRELIMINARY SERVICE CHECKS

Enclosed

SAFETY PRECAUTIONS

See page 18.

INDEX

	Page		Page
Adjustments	8	Photos	
Block Diagram	15	Main Board	4,5,16,17
Disassembly Instructions	21	Main Board- Shield Location	20
General Operating Instructions	6	Schematics	
GridTrace Location Guide		IC Pinouts & Terminal Guides	3
Main Board	4,17	Main Board	2
Line Definitions	18	Notes	19
Logic Chart	13,14	Troubleshooting	6,7,8
Parts List	9 thru 12		

SAMS™ Howard W. Sams & Co., Inc.
4300 West 62nd Street, P.O. Box 7092, Indianapolis, Indiana 46206 U.S.A.

The listing of any available replacement part herein does not constitute in any case a recommendation, warranty or guaranty by Howard W. Sams & Co., Inc., as to the quality and suitability of such replacement part. The numbers of these parts have been compiled from information furnished to Howard W. Sams & Co., Inc., by the manufacturers of the particular type of replacement part listed.

Reproduction or use, without express permission, of editorial or pictorial content, in any manner, is prohibited. No patent liability is assumed with respect to the use of the information contained herein.

© 1984 Howard W. Sams & Co., Inc.
4300 West 62nd Street, P.O. Box 7092, Indianapolis, Indiana 46206 U.S.A.
Printed in U.S. of America. 84CF14909 DATE 5-84



COMPUTERFACTS-OF-THE-MONTH SET NO. CF2 FOLDER CC3

SCHEMATIC NOTES

—*— Circuitry not used in some versions

--- Circuitry used in some versions

⊙ See parts list

⊕ Ground

Item numbers in rectangles appear in the alignment/adjustment instructions.

Supply voltage maintained as shown at input.

Voltages measured with digital meter.

Voltages and Waveforms taken with computer in Power Up mode (Main title screen displayed) unless otherwise noted.

Waveforms taken with triggered scope and Sweep/Time switch in Calibrate position, scope input set for DC coupling on "O" reference voltage waveforms. Switch to AC input to view waveforms after DC reference is measured when necessary. Each waveform is 9 cm width with DC reference voltage given at the bottom line of each waveform. Time in $\mu\text{sec. per cm}$, given with p-p reading at the end of each waveform.

Terminal identification may not be found on unit.

Resistors are 1/2W or less, 5% unless noted.

Value in () used in some versions.

NOTE: Logic probe readings taken after computer turned on, no keys pressed, unless otherwise noted.

Logic Probe Display

L = Low

H = High

P = Pulse

* = Open (No lights on)

- (1) Goes low when RESTORE key is pressed.
- (2) Pulses appear while saving a program to cassette tape.
- (3) Pulses appear while loading a program from cassette tape.
- (4) Goes low when cassette recorder is put in Play or Record mode.
- (5) Goes low to turn cassette recorder on.
- (6) Pulses appear when — , 1, 2, CTRL, Q, RUN/STOP, CMD or SPACE key is pressed.
- (7) Pulses appear when 3, 4, W, E, SHIFT LOCK, A, S, LEFT SHIFT or Z key is pressed.
- (8) Pulses appear when 5, 6, T, R, D, F, X or C key is pressed.
- (9) Pulses appear when 7, 8, Y, U, G, H, V or B key is pressed.
- (10) Pulses appear when 7, 9, 0, R, Y, I, O, G, J, K, N or M key is pressed.
- (11) Pulses appear when +, — , P, @, L, :, . or COMMA key is pressed.
- (12) Pulses appear when £, CLR/HOME, *, !, ;, =, / or RIGHT SHIFT key is pressed.
- (13) Pulses appear when INST/DEL, RETURN, CRSR, CRSR, F1, F3, F5, or F7 key is pressed.
- (14) Pulses appear for all keys except RESTORE.

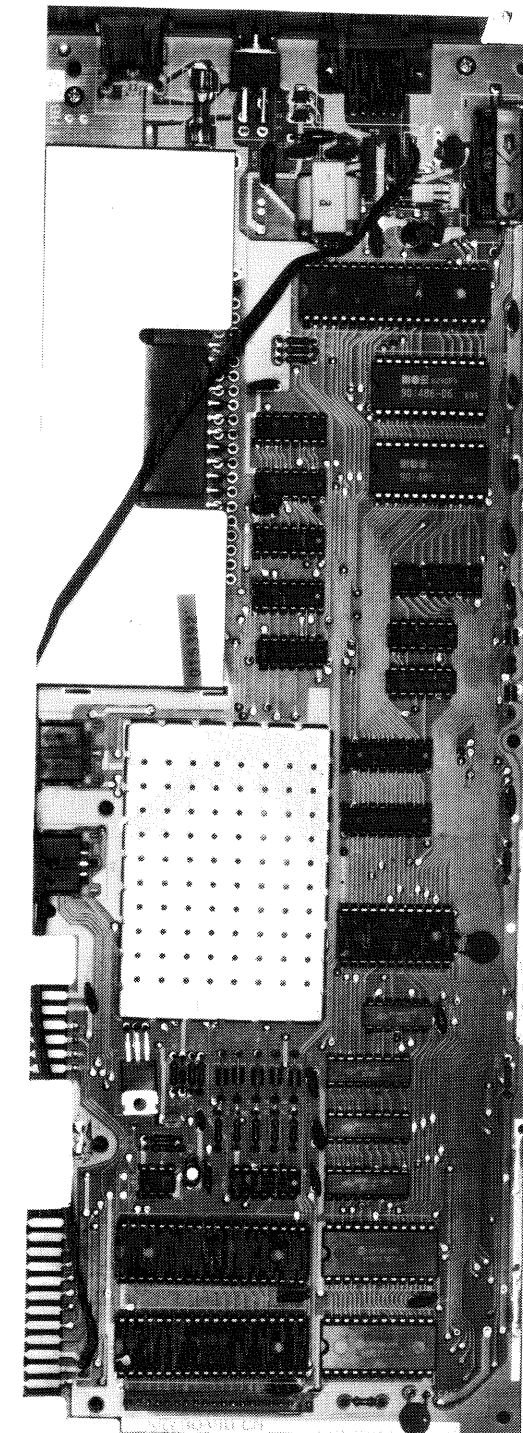

COMMODORE
MODEL VIC 20

THIS WAVEFORM TAKEN AT PINS 10, 11, 12 AND 14 THRU 17 OF UAB1

WAVEFORM TAKEN WHILE LOADING A PROGRAM TO TAPE (HEADER SIGNAL)

WAVEFORM TAKEN WHILE SAVING A PROGRAM TO TAPE (HEADER SIGNAL)

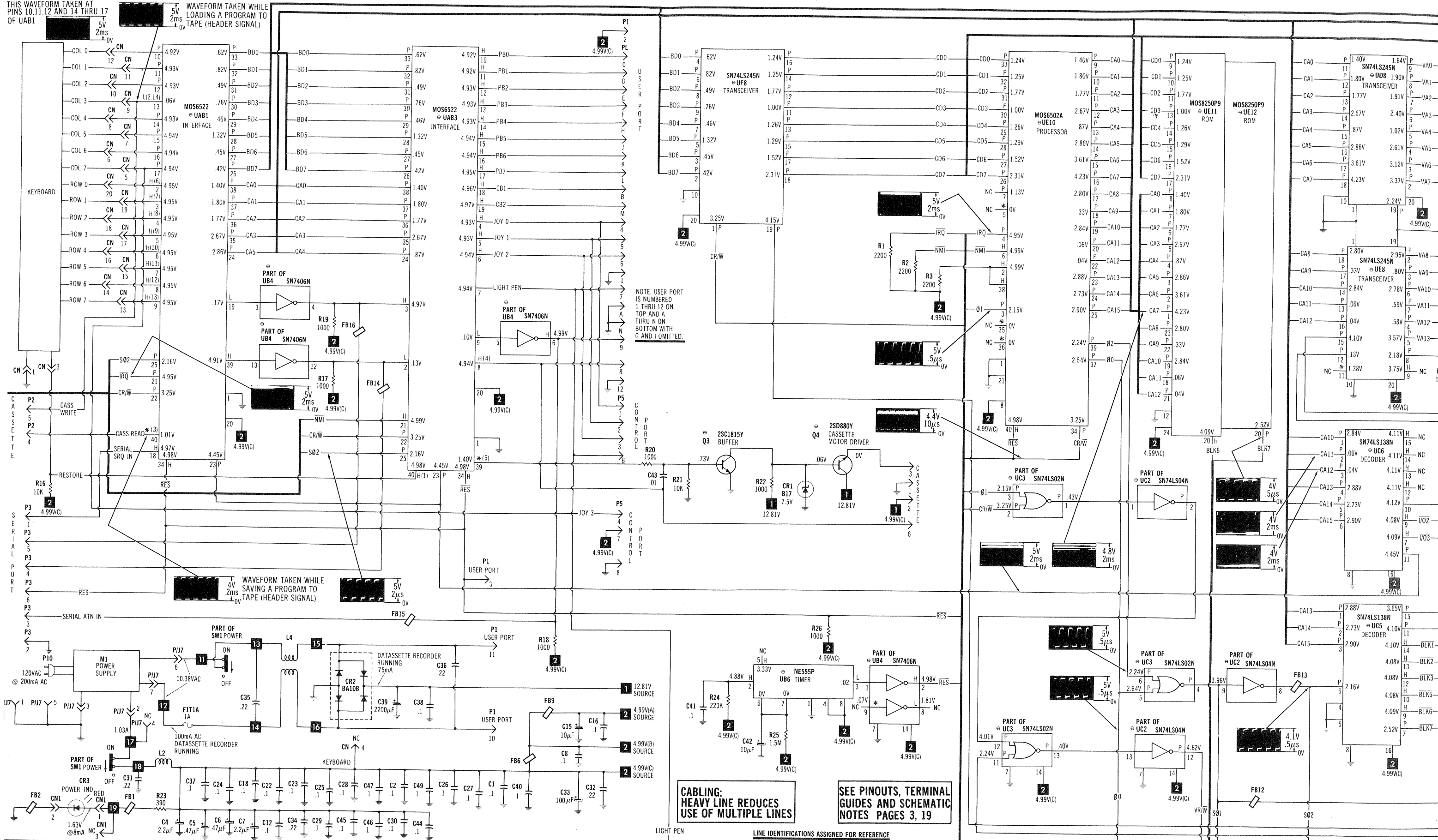

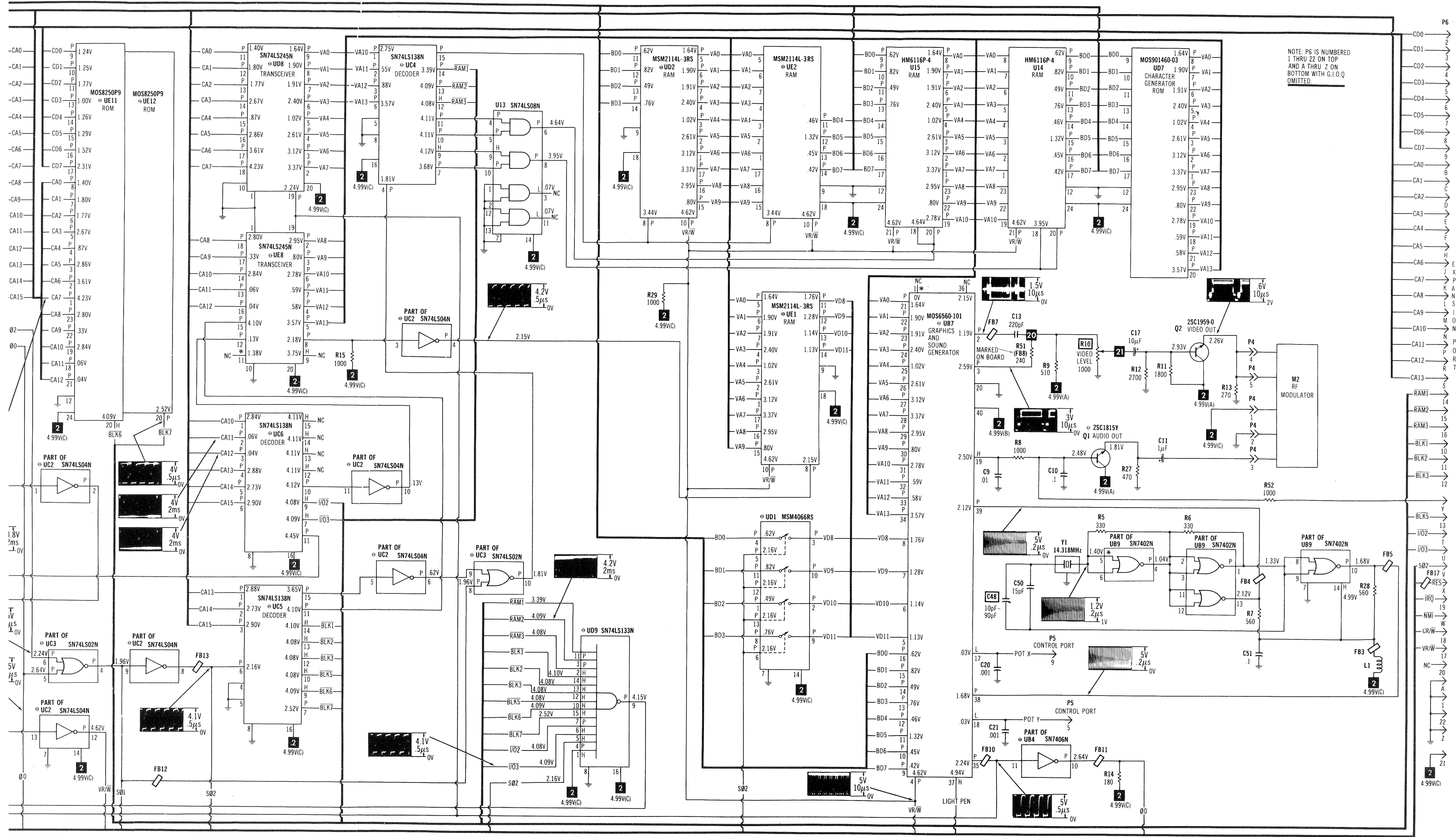

NOTE: P6 IS NUMBERED 1 THRU 22 ON TOP AND A THRU Z ON BOTTOM WITH G.I.O.Q. OMITTED.

SEE LINE DEFINITIONS ON PAGE 18

COMMODORE
MODEL VIC-20

LINE DEFINITIONS

BD0 Thru BD7 Basic Data Lines
 BLK1 Thru BLK7 Memory Blocks
 CA0 Thru CA15 Control Address Lines
 CASS READ Cassette Read
 CASS WRITE Cassette Write
 CB1, CB2 Port Control Lines
 CD0 Thru CD7 Control Data Lines
 COL0 Thru COL7 Keyboard Columns
 CR/W Control Read/Write
 I/O Input/Output
 IRQ Interrupt Request
 JOY0 Joystick 0
 JOY1 Joystick One
 JOY2 Joystick Two
 JOY3 Joystick Three
 LIGHT PEN Light Pen
 NMI Non-Maskable Interrupt

PB0 Thru PB7 Port Data Lines
 POT X Potentiometer Grid X
 POT Y Potentiometer Grid Y
 RAM1 Thru RAM3 RAM Expansion Port Select
 RES Reset
 RESTORE Restore
 ROW1 Thru ROW7 Keyboard Rows
 SØ1 Select Phase One
 SØ2 Select Phase Two
 SERIAL ATN IN Serial Attention Input
 SERIAL SRQ IN Serial Select Request Input
 VA0 Thru VA13 Video Address Lines
 VD8 Thru VD11 Video Data Lines
 VR/W Video Read/Write
 Ø0 Phase 0
 Ø1 Phase One
 Ø2 Phase Two

Any Bar above any alphabetical or numerical combination indicates line active in a low (0) state.

SAFETY PRECAUTIONS

1. Use an isolation transformer for servicing.
2. Maintain AC line voltage at rated input.
3. Remove AC power from the computer before servicing or installing electrostatically sensitive devices. Examples of typical ES devices are integrated circuits and semiconductor "chip" components.
4. Use extreme caution when handling the printed circuit boards. Some semiconductor devices can be damaged easily by static electricity. Drain off any electrostatic charge on your body by touching a known earth ground. Wear a commercially available discharging wrist strap device. This should be removed prior to applying power to the unit under test.
5. Use a grounded-tip, low voltage soldering iron.
6. Use an isolation (times 10) probe on scope.
7. Do not remove or install boards, floppy disk drives, printers, or other peripherals with computer AC power On.
8. Do not use freon-propelled sprays. These can generate electrical charges sufficient to damage semiconductor devices.
9. Periodically examine the AC power cord for damaged or cracked insulation.
10. The computer cabinet is equipped with vents to prevent heat build-up. Never block, cover, or obstruct these vents.
11. Instructions should be given, especially to children, that objects should not be dropped or pushed into the vents of the cabinet. This could cause shock or equipment damage.
12. Never expose the computer to water. If exposed to water turn the unit off. Do not place the computer near possible water sources.
13. Never leave the computer unattended or plugged into the AC outlet for long periods of time. Remove AC plug from AC outlet during lightning storms.
14. Do not allow anything to rest on AC power cord.
15. Unplug AC power cord from outlet before cleaning computer.
16. Never use liquids or aerosols directly on the computer. Spray on cloth and then apply to the computer cabinet. Make sure the computer is disconnected from the AC power line.

IC PINOUTS & TERMINAL GUIDES

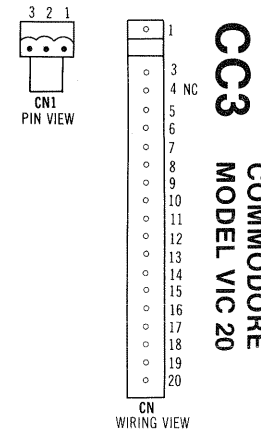
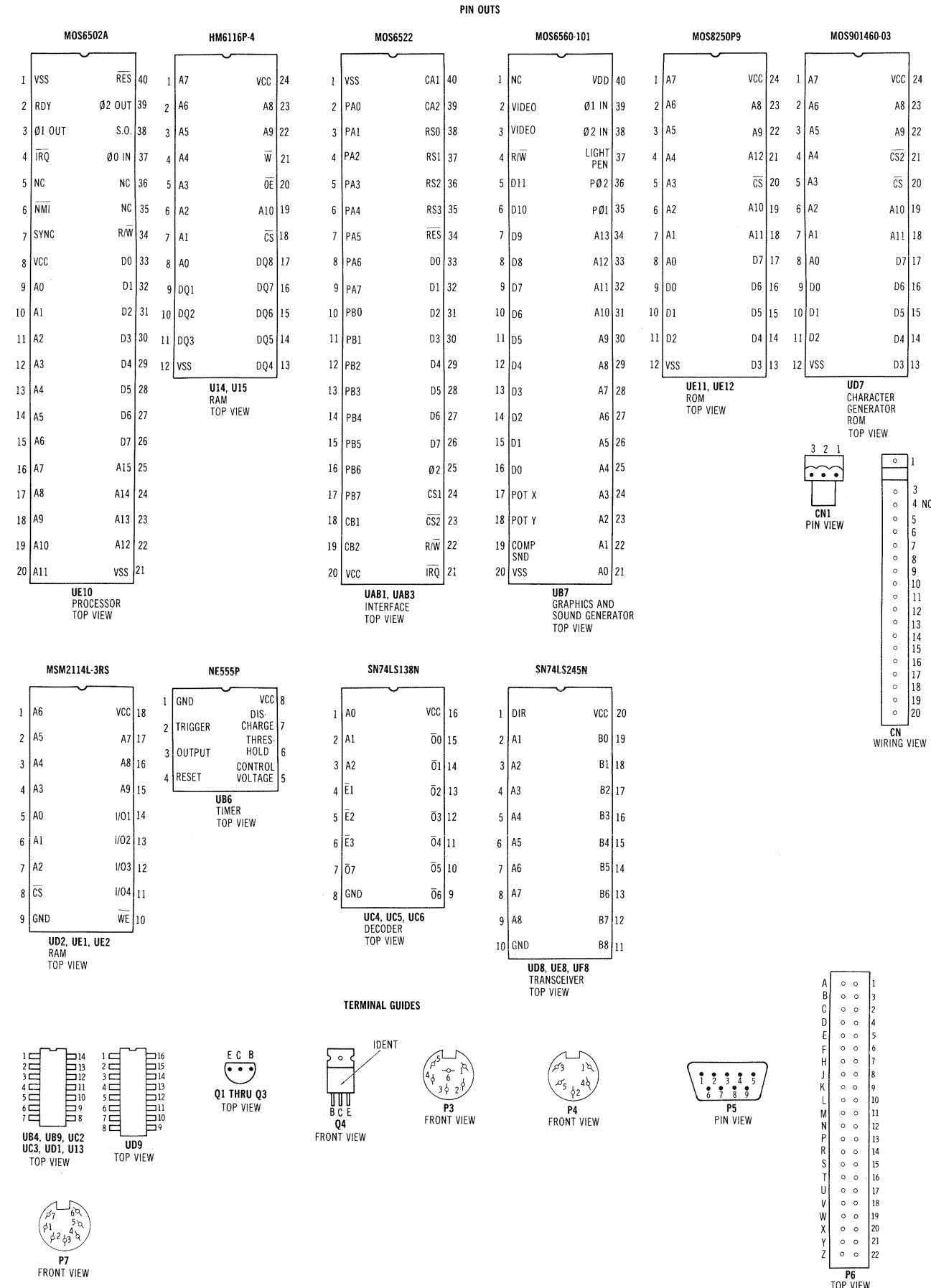

MAIN BOARD GridTrace LOCATION GUIDE

C1	K-24	C17	D-12	C33	H-26	C47	K-14	FB5	G-14	L4	G-27	R3	F-24	R18	F-7	SW1	E-30	UC6	F-19
C2	K-18	C18	G-6	C34	H-26	C48	C-14	FB6	E-14	P1	A-3	R5	C-14	R19	F-7	U13	F-17	UD1	I-9
C4	C-12	C20	F-29	C35	E-28	C49	K-20	FB7	E-13	P2	A-9	R6	D-14	R20	D-8	U14	H-4	UD2	H-6
C5	C-14	C21	F-29	C36	H-28	C50	D-13	FB9	E-12	P3	A-12	R7	F-15	R21	D-8	U15	H-2	UD7	H-11
C6	C-13	C22	G-8	C37	F-1	C51	F-15	FB10	G-12	P4	A-15	R8	E-10	R22	D-8	UAB1	E-2	UD8	H-15
C7	D-13	C23	G-7	C38	I-28	CN	E-1	FB11	F-8	P5	G-30	R9	E-12	R23	H-27	UAB3	E-4	UD9	F-21
C8	F-14	C24	I-1	C39	J-28	CN1	I-27	FB12	K-18	P6	C-22	R10	D-12	R24	D-6	UB4	F-6	UE1	H-8
C9	E-10	C25	J-9	C40	I-26	CR1	D-8	FB13	K-16	P7	B-30	R11	E-11	R25	D-7	UB6	D-6	UE2	H-7
C10	D-10	C26	K-21	C41	E-6	CR2	G-28	FB14	E-8	Q1	D-10	R12	E-11	R26	E-7	UB7	F-12	UE8	H-14
C11	D-10	C28	J-11	C42	D-6	F1T1A	D-29	FB15	F-8	Q2	D-11	R13	E-10	R27	D-10	UB9	E-15	UE10	H-25
C12	C-11	C29	E-23	C43	D-7	FB1	H-27	FB16	F-8	Q3	D-7	R14	F-7	R28	F-15	UC2	I-16	UE11	I-21
C13	D-13	C30	G-3	C44	B-10	FB2	J-27	FB17	E-8	Q4	C-8	R15	K-13	R29	K-8	UC3	I-17	UE12	I-25
C15	E-12	C31	F-28	C45	E-20	FB3	D-15	L1	D-15	R1	F-23	R16	H-11	R51	E-13	UC4	F-18	UF8	I-19
C16	E-11	C32	G-28	C46	I-3	FB4	G-15	L2	F-28	R2	F-24	R17	E-7	R52*	C-18	UC5	F-22	Y1	C-15

* Located on other side of board.

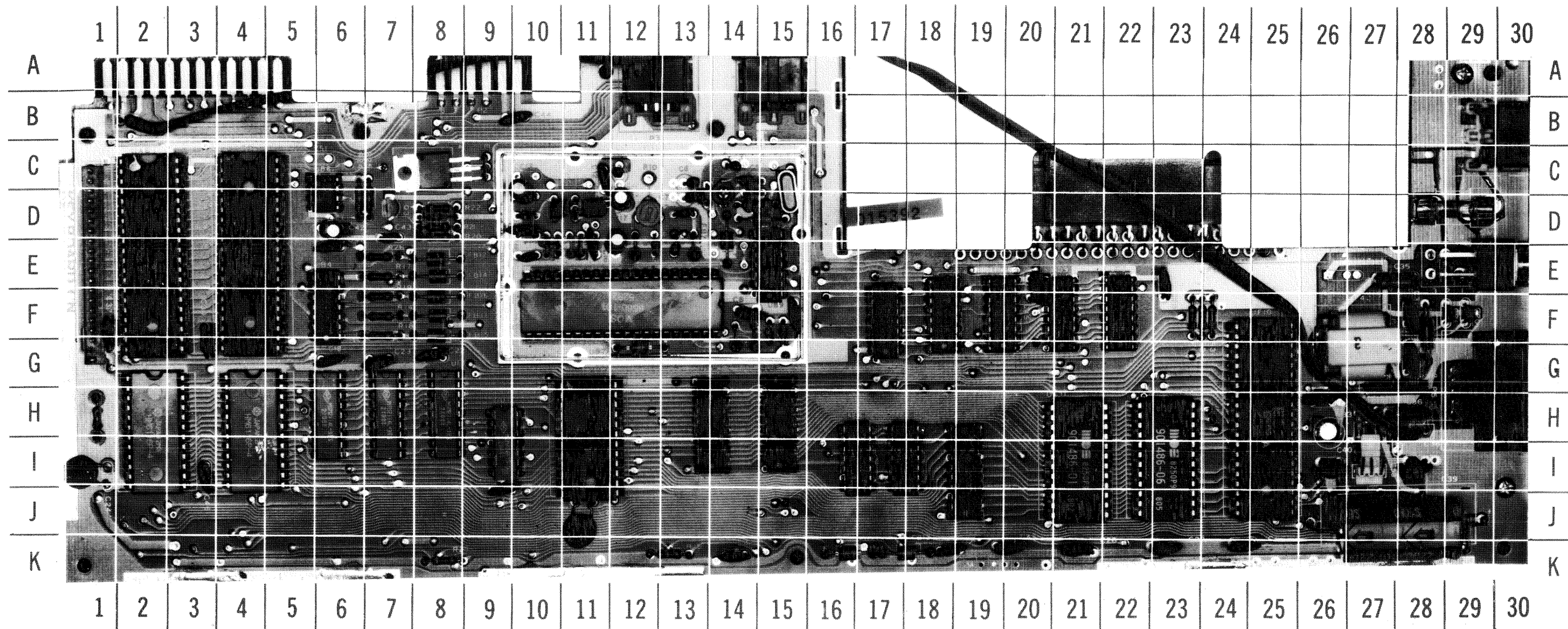

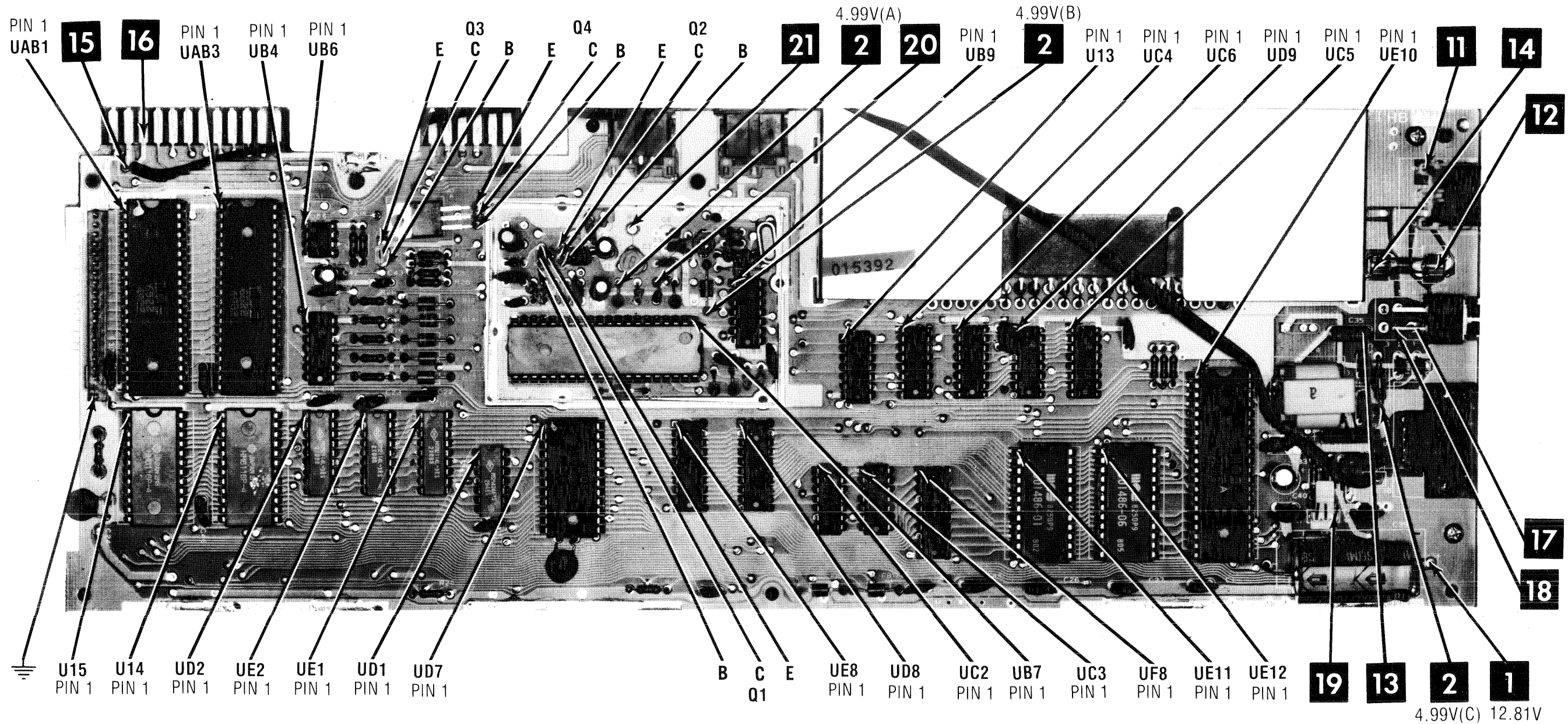

CC3
COMMODORE
MODEL VIC 20

GENERAL OPERATING INSTRUCTIONS

POWER UP

When the computer is turned On, it will come up ready to program in Commodore Basic. See "Cassette Operation" for instructions on loading and saving programs. To run a program after it is loaded, type RUN and press the RETURN key. To stop a program press the RUN/STOP key. Pressing the RUN/STOP key and RESTORE key at the same time will stop the program and reset the computer to the start condition, without losing the program.

TROUBLESHOOTING

POWER SUPPLY

Computer does not power up at turn-on. While Power Supply (M1) remains plugged into a known good AC source, carefully disconnect the Power Supply Plug (P7) from the computer and check for 5.00V from pin 2 to pin 3 of Plug P7. If the voltage is missing, replace the Power Supply. If the voltage is present, check for 4.99V at Source 2.

If 4.99V is missing at Source 2, check On-Off Switch (SW1), Coil L2 and check for possible shorts to ground.

Datassette cassette motor does not run. While Power Supply (M1) remains plugged into a known good AC source, carefully disconnect the Power Supply Plug P7 from the computer and check for 10.38 VAC from pin 6 to pin 7 of Plug P7. If the voltage is missing, replace the Power Supply. If 10.38 VAC is present, check for 12.81V at Source 1.

If 12.81V is missing at Source 1, check the Bridge Rectifier (CR2), Line Filter (L4), Fuse F1T 1A and On-Off Switch (SW1). If 12.81V is present, refer to the "Cassette Save and Load" section of this Troubleshooting guide.

MICROPROCESSOR CHIP (CPU) OPERATION

To verify the processor is working, use a logic probe to check for pulses on the data lines (pins 26 thru 33 of IC UE10) and the address lines (pins 9 thru 20 and 22 thru 25 of IC UE10). If the processor is not working, check pin 40 of IC UE10 with the logic probe while the computer is turned Off and then On again.

The probe should read low for about two seconds after turn-on, then read high to reset the processor. If the probe reading is incorrect, check the voltages and components associated with the Reset IC (UB6). If the reading is correct, check for pulses on pin 4 and a high indication on pin 6 of IC UE10.

Should the reading on pin 4 of IC UAB1 or the reading on pin 6 of IC UAB3 be incorrect, check each IC by substituting a good IC. Check for pulses on pin 34 of IC UE10 and check the voltages on pins 2, 8 and 38 of IC UE10. Check the clock waveforms at pins 37 and 39 of IC UE10.

CRYSTAL OSCILLATOR

Verify that the crystal oscillator is operating by checking the waveform on pin 39 of IC UB7. Also, check the frequency with a frequency counter connected to pin 2 of IC UB9.

CASSETTE OPERATION

Plug the Datassette cassette recorder into the six pin edge connector on the rear of the computer. Note: A regular cassette tape recorder will not work on the VIC 20. To load a program, type LOAD, press the RETURN key and follow the instructions displayed on the Monitor screen. To save a program, type SAVE, press the RETURN key and follow the instructions displayed on the screen.

VIDEO

When there is no video, check for a .6V peak to peak video waveform at pin 4 of Socket P4. If the waveform is good, check the RF Modulator unit by substituting a good RF Modulator unit. If the waveform is absent, check for a video waveform at pin 2 of IC UB7.

For a missing waveform at pin 2, check IC UB7 by substituting a good IC and checking the 14.318MHz Oscillator operation.

If the waveform at pin 2 of IC UB7 is good, check the voltages and components associated with Transistor Q2 and check the adjustment of the Video Level Control (R10).

COLOR

No color. Check for a color waveform at pin 3 of IC UB7. If the waveform is missing at pin 3, check IC UB7 by substituting a good IC.

Colors are incorrect. Check the adjustments of the 14MHz Oscillator Trimmer (C48) and the Video Level Control (R10). Also, check IC UB7, Capacitors C35 and C36 and Diode CR3.

AUDIO

No sound. Type POKE 36878,15 and press the RETURN key. Then type POKE 36875,222 and press the RETURN key. Check for the waveform shown in Figure 1 at pin 19 of IC UB7.

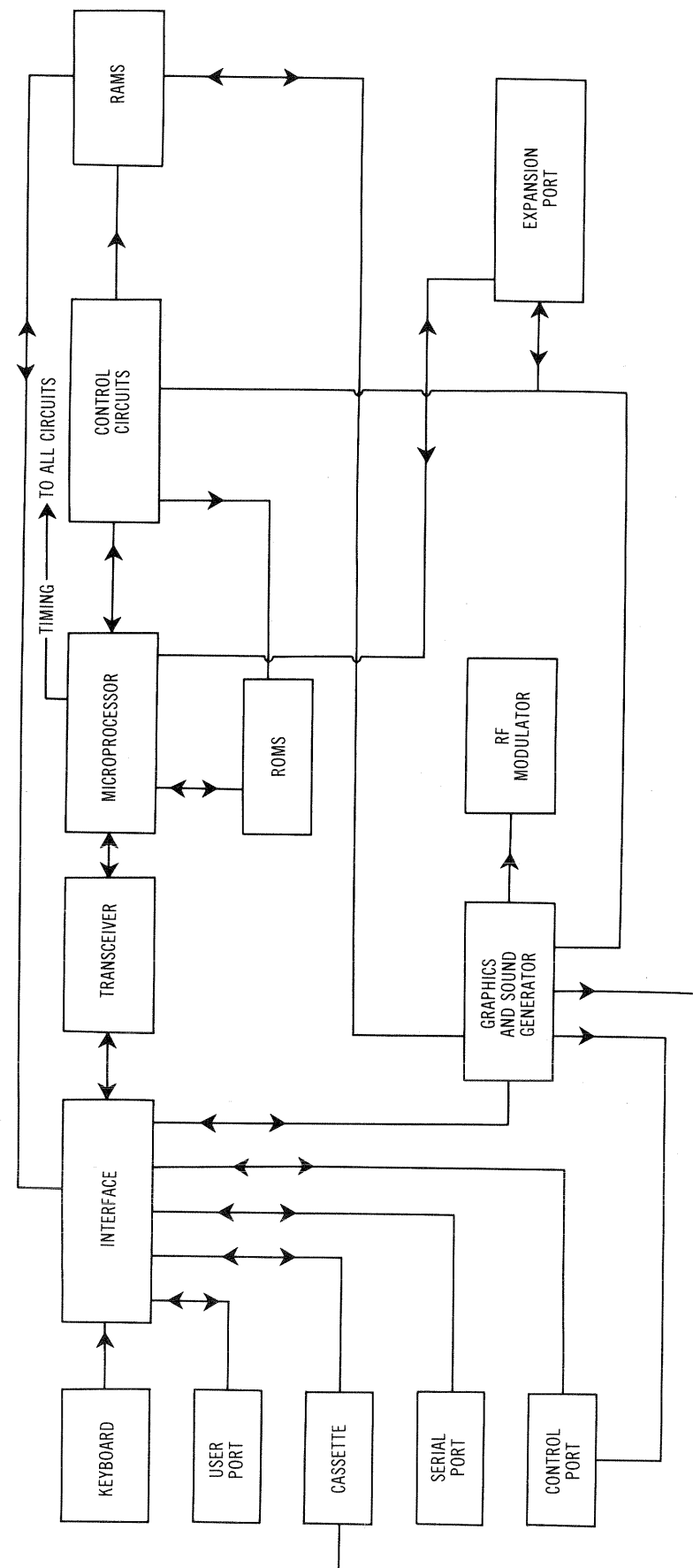

Figure 1

1.8V
2ms
0V
DC Reference

If the waveform is missing, check for possible shorts at pin 19 of IC UB7. Check IC UB7 by substituting a known good IC. If the waveform at pin 19 is good, check for a 1.8V peak to peak waveform at pin 3 of Socket P4.

For a missing waveform at pin 3, check the voltages and components associated with Transistor Q1. If the waveform at pin 3 is good, check the RF Modulator by substituting a good RF Modulator unit.



BLOCK DIAGRAM

COMMODORE
MODEL VIC 20

LOGIC (Continued)

PIN NO.	IC UB7	PIN NO.	IC UB7	PIN NO.	IC UB9	IC UC2	IC UC3	IC UC4	IC UC5	IC UC6	IC UD1	IC UD2	IC UD7	IC UD8
1	*	21	P	1	P	P	P	P	P	P	P	P	P	L
2	P	22	P	2	P	P	P	P	P	P	P	P	P	P
3	P	23	P	3	P	P	P	P	P	P	P	P	P	P
4	P	24	P	4	P	P	P	P	L	P	P	P	P	P
5	P	25	P	5	*	P	P	L	L	P	P	P	P	P
6	P	26	P	6	*	P	P	L	P	P	P	P	P	P
7	P	27	P	7	L	L	L	P	P	H	L	P	P	P
8	P	28	P	8	L	L	L	L	L	L	P	P	P	P
9	P	29	P	9	P	P	P	H	H	H	P	L	P	P
10	P	30	P	10	P	P	P	P	H	H	P	P	P	L
11	P	31	P	11	P	P	P	P	H	H	P	P	P	P
12	P	32	P	12	P	P	P	H	H	H	P	P	L	P
13	P	33	P	13	P	H	H	P	H	H	P	P	P	P
14	P	34	P	14	H	H	H	P	H	H	H	P	P	P
15	P	35	P	15				P	H	H		P	P	P
16	P	36	P	16				H	H	H		P	P	P
17	L	37	H	17								P	P	P
18	L	38	P	18								H	P	P
19	H	39	P	19									P	P
20	L	40	H	20									P	H
				21									P	
				22									P	
				23									P	
				24									H	

PIN NO.	IC UD9	IC UE1	IC UE2	IC UE8	PIN NO.	IC UE10	PIN NO.	IC UE10	PIN NO.	IC UE11	IC UE12	IC UF8
1	H	P	P	L	1	L	21	L	1	P	P	P
2	H	P	P	P	2	H	22	P	2	P	P	P
3	P	P	P	P	3	P	23	P	3	P	P	P
4	P	P	P	P	4	P	24	P	4	P	P	P
5	H	P	P	P	5	*	25	P	5	P	P	P
6	H	P	P	P	6	H	26	P	6	P	P	P
7	P	P	P	P	7	P	27	P	7	P	P	P
8	L	P	P	P	8	H	28	P	8	P	P	P
9	P	L	L	H	9	P	29	P	9	P	P	P
10	H	P	P	L	10	P	30	P	10	P	P	L
11	P	P	P	*	11	P	31	P	11	P	P	P
12	H	P	P	P	12	P	32	P	12	L	L	P
13	H	P	P	P	13	P	33	P	13	P	P	P
14	H	P	P	P	14	P	34	P	14	P	P	P
15	H	P	P	P	15	P	35	*	15	P	P	P
16	H	P	P	P	16	P	36	*	16	P	P	P
17		P	P	P	17	P	37	P	17	P	P	P
18		H	H	P	18	P	38	H	18	P	P	P
19				P	19	P	39	P	19	P	P	P
20				H	20	P	40	H	20	H	P	H
21									21	P	P	
22									22	P	P	
23									23	P	P	
24									24	H	H	

NOTE: Logic probe readings taken after computer turned on, no keys pressed, unless otherwise noted.

Logic Probe Display
 L = Low
 H = High
 P = Pulse
 * = Open (No lights on)

TROUBLESHOOTING (Continued)

Type and enter the following program to check the volume control, three tone channels and noise channel features of IC UB7. When the program is run, three different tones and noise should be heard with the volume gradually increasing to MAXIMUM.

```

10 FOR X = 1 TO 15
20 POKE 36878,X
30 FOR Y = 36874 TO 36877
40 POKE Y, 222
50 FOR T = 1 TO 300: NEXT T
60 POKEY, 0
70 NEXT Y: NEXT X
    
```

KEYBOARD

Keyboard is not working. Check the waveforms at pins 10, 11, 12 and 14 thru 17 of IC UAB1. If any of the waveforms are missing, check IC UAB1 by substituting a good IC. If the waveforms are good, check the operation of the keyboard. Using a Logic Probe, check the readings on pins 2 thru 9 and pin 13 of IC UAB1. See "Logic Chart".

For incorrect readings, check the keyboard connector and check the switches on the keyboard with an ohmmeter. If the readings are good, check IC UAB1 by substituting a good IC.

RESTORE key is not working. Check for 0V on pin 40 of IC UAB3 when the RESTORE key is pressed. If the voltage does not drop to 0V, check the pin 3 connection on the keyboard connector and check the RESTORE key switch with an ohmmeter. If the voltage checks good, check IC UAB3 by substituting a good IC.

JOYSTICK

Joystick is not working properly. Check the voltages on those pins associated with the particular joystick position as it is activated. See chart below. The voltage should go from about 5V to less than .5V.

IC	PIN	JOYSTICK POSITION
UAB1	17	RIGHT
UAB3	4	UP
UAB3	5	DOWN
UAB3	6	LEFT
UAB3	7	BUTTON

If any voltage is not correct, check the joystick switches and Plug P5. Also, check IC UAB1 or UAB3 by substituting a good IC.

If the voltages are correct, check IC UAB1 or UAB3 by substituting a good IC.

Check the operation of the joystick by loading and running a program that uses the joystick or type, enter and run the following program.

```

10 POKE 37139, 0
20 POKE 37154, 0
30 X = PEEK (37137)
40 Y = PEEK (37152)
50 PRINT "X = "; X, "Y = "; Y
60 FOR T = 1 TO 400: NEXT T
70 GOTO 30
    
```

The numbers for X and Y that appear on the monitor screen should be the same as those shown in the chart below for the appropriate joystick position.

JOYSTICK POSITION	X	Y
CENTER	254	255
UP	250	255
DOWN	246	255
LEFT	238	255
RIGHT	254	127
BUTTON	222	255

NOTE: Other numbers will appear if two switches on the joystick are closed at the same time.

PADDLES

Buttons on the paddles do not work. Check the voltages on pin 6 of IC UAB3 and pin 17 of IC UAB1 while the appropriate button is being pressed. The voltage should go from 5V to 0V when the button is pressed. If the voltage does not change, check the button switches and pins 3, 4 and 8 at Plug P5 for good connection. If the voltages are good, check IC's UAB1 and UAB3 by substituting good IC's.

Paddles do not work. Check the paddle inputs by connecting a 100K ohm resistor from pin 5 to pin 7 of Plug P5 and another 100K ohm resistor from pin 9 to pin 7 of Plug P5. Then, check for the waveform shown in Figure 2 at pins 17 and 18 of IC UB7.

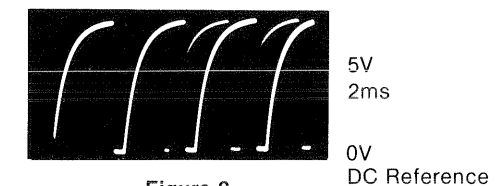

Figure 2

If the waveforms are good, check the paddles. Also, check for good connections at pins 5, 7 and 9 of Plug P5. If the waveforms are missing, check IC UB7 by substitution.

CASSETTE SAVE AND LOAD

Computer will not save a program to cassette tape. Check the waveform on pin 13 of IC UAB1 while saving a program to tape. If the waveform is missing, check IC UAB1 by substituting a good IC. If the waveform is present, check the connections at pin 5 of Plug P2.

CC3
 COMMODORE
 MODEL VIC 20

TROUBLESHOOTING (Continued)

Computer will not load a program from cassette tape. Check the waveform on pin 40 of IC UAB1 while loading a program from tape. If the waveform is present at pin 40, check IC UAB1 by substituting a good IC. If the waveform is missing at pin 40, check the connection at pin 4 of Plug P2.

Datassette cassette motor will not start when the cassette recorder is put in Play or Record mode. Check the voltage on pin 8 of IC UAB3. The voltage on pin 8 should go from 5V to 0V when the recorder is put in Play or Record mode. If the voltage on pin 8 does not change, check the connection at pin 6 of Plug 2. If the voltage on pin 8 is good, check the voltage on pin 39 of IC UAB3.

The voltage on pin 39 should read about .05V when the recorder is put in Play or Record mode. If the voltage on pin

39 is incorrect, check IC UAB3 by substituting a good IC. If the voltage on pin 39 is good, check the voltages and components associated with Transistors Q3 and Q4. See the following chart for voltages with the recorder in Play or Record mode and the motor running. If 12.81V is missing from the collector of Transistor Q4, refer to the "Power Supply" section of this Troubleshooting guide.

	E	B	C
Q3	0V	.05V	6.86V
Q4	6.24V	6.86V	12.81V

Note: Voltages measured with Datassette cassette recorder in Play or Record mode, motor running.

ADJUSTMENTS

VIDEO LEVEL

Connect the input of a scope to pin 5 of Socket P4 and adjust the Video Level Control (R10) for a video level of .6V peak to peak.

14MHz OSCILLATOR

Connect the input of a frequency counter to pin 2 of IC UB9 and adjust the 14MHz Oscillator Trimmer for a frequency of 14.31818MHz.

LOGIC

PIN NO.	IC U13	IC U14	IC U15	PIN NO.	IC UAB1	PIN NO.	IC UAB1	PIN NO.	IC UAB3	PIN NO.	IC UAB3	PIN NO.	IC UB4	IC UB6
1	L	P	P	1	L	21	P	1	L	21	H	1	L	L
2	L	P	P	2	H(6)	22	P	2	L	22	P	2	H	H
3	L	P	P	3	H(7)	23	P	3	H	23	P	3	L	L
4	P	P	P	4	H(8)	24	P	4	H	24	P	4	H	H
5	P	P	P	5	H(9)	25	P	5	H	25	P	5	L	H
6	P	P	P	6	H(10)	26	P	6	H	26	P	6	H	L
7	L	P	P	7	H(11)	27	P	7	H	27	P	7	L	L
8	P	P	P	8	H(12)	28	P	8	H(4)	28	P	8	L	H
9	H	P	P	9	H(13)	29	P	9	L	29	P	9	*	
10	P	P	P	10	P	30	P	10	H	30	P	10	P	P
11	L	P	P	11	P	31	P	11	H	31	P	11	P	P
12	L	L	L	12	P	32	P	12	H	32	P	12	L	L
13	L	P	P	13	L (2,14)	33	P	13	H	33	P	13	H	H
14	H	P	P	14	P	34	H	14	H	34	H	14	H	H
15		P	P	15	P	35	P	15	H	35	P	15		
16		P	P	16	P	36	P	16	H	36	P	16		
17		P	P	17	P	37	P	17	H	37	P	17		
18		P	P	18	H	38	P	18	H	38	P	18		
19		P	P	19	L	39	H	19	H	39	*(5)	19		
20		P	P	20	H	40	*(3)	20	H	40	H(1)	20		
21		P	P									21		
22		P	P									22		
23		P	P									23		
24		H	H									24		

NOTE: Logic probe readings taken after computer turned on, no keys pressed, unless otherwise noted.

Logic Probe Display

L = Low
H = High
P = Pulse
* = Open (No lights on)

- (1) Goes low when RESTORE key is pressed.
- (2) Pulses appear while saving a program to cassette tape.
- (3) Pulses appear while loading a program from cassette tape.
- (4) Goes low when cassette recorder is put in Play or Record mode.
- (5) Goes low to turn cassette recorder on.

- (6) Pulses appear when --, 1, 2, CTRL, Q, RUN/STOP, CMD or SPACE key is pressed.
- (7) Pulses appear when 3, 4, W, E, SHIFT LOCK, A, S, LEFT SHIFT or Z key is pressed.
- (8) Pulses appear when 5, 6, T, R, D, F, X or C key is pressed.
- (9) Pulses appear when 7, 8, Y, U, G, H, V or B key is pressed.
- (10) Pulses appear when 7, 9, 0, R, Y, I, O, G, J, K, N or M key is pressed.
- (11) Pulses appear when +, -, P, @, L, :, . or COMMA key is pressed.
- (12) Pulses appear when £, CLR/HOME, *, !, ;, =, / or RIGHT SHIFT key is pressed.
- (13) Pulses appear when INST/DEL, RETURN, CRSR, CRSR, F1, F3, F5, or F7 key is pressed.
- (14) Pulses appear for all keys except RESTORE.

COMMODORE
MODEL VIC 20

PARTS LIST AND DESCRIPTION (Continued)

When ordering parts, state Model, Part Number, and Description

FUSE DEVICES

ITEM No.	DESCRIPTION	REPLACEMENT DATA				NOTES
		MFR. PART No.		BUSS PART No.		
		DEVICE	HOLDER	DEVICE	HOLDER	
F1T1A	1A @ 250V Fast-Acting					

MISCELLANEOUS

ITEM No.	PART NAME	MFR. PART No.	NOTES
CR3 FB1 thru FB7 FB9 thru FB17	LED Ferrite Bead Ferrite Bead		1.63V @ 8mA, Red
M1 M2 P10 SW1 Y1	Power Supply RF Modulator Cord Switch Crystal Antenna Switch Keyboard	P/N251052-02 904778-01	AC Power On-Off 14.318MHz Computer-TV

CABINET & CABINET PARTS (When ordering specify model, chassis & color)

PARTS LIST AND DESCRIPTION

When ordering parts, state Model, Part Number, and Description

SEMICONDUCTORS (Select replacement for best results)

ITEM No.	TYPE No.	MFR. PART No.	REPLACEMENT DATA							
			EGG PART No.	GENERAL ELECTRIC PART No.	MOTOROLA PART No.	NTE PART No.	RCA PART No.	WORKMAN PART No.	ZENITH PART No.	
CR1 CR2 Q1 Q2 Q3 Q4 U13 U14, 15 UAB1 UAB3 UB4 UB6 UB7 UB9 UC2 UC3 UC4, 5 & 6 UD1 UD2	B17 BA10B 2SC1815Y 2SC1815 2SC1959-0 2SC1815Y 2SC1815 2SD880Y 2SD880 SN74LS08N HM6116P-4 MOS6522 MPS6522 MOS6522 MPS6522 SN7406N 7406 NE555P NE555 MOS6560-101 MPS6560 SN7402N SN74LS04N 74S04 SN74LS02N 74S02 SN74LS138N 74LS138 MSM4066RS 4066 MSM2114L-3RS		EGG5015A EGG85 EGG85 EGG85 EGG85 EGG85 EGG152 EGG152 EGG74LS08 EGG7406 EGG7406 EGG955M EGG955M EGG7402 EGG74LS04 EGG74S04 EGG74LS02 EGG74S02 EGG74LS138 EGG74LS138 EGG4066B EGG4066B EGG2114	GEZD-7.5 GE-62 GE-62 GE-210 GE-62 GE-62 GE-66A GE-66A	1N5236B MPSA05* MPSA05* 2N4401* MPSA05* MPSA05* TIP41A TIP41A SN74LS08N	NTE5015A NTE85 NTE85 NTE85 NTE85 NTE85 NTE152 NTE152 NTE74LS08 NTE7406 NTE7406 NTE955M NTE955M NTE7402 NTE74LS04 NTE74S04 NTE74LS02 NTE74S02 NTE74LS138 NTE74LS138 NTE4066B NTE4066B NTE2114	SK7A5/5015A SK3124A/289A SK3124A/289A SK3124/289 SK3124A/289A SK3124A/289A SK3440/291 SK3440/291 SK74LS08 SK7406 SK7406 SK3564/955M SK3564/955M SK7402 SK74LS04 SK74S04 SK74LS02 SK74LS02 SK74LS138 SK74LS138 SK4066B SK4066B SK4066B	WEP1416/5015 WEP66/199 WEP66/199 WEP910/289 WEP66/199 WEP66/199 WEP745/152 WEP745/152 WEP2119/955M WEP2119/955M WEP7402/7402 WEP4066B/4066B WEP4066B/4066B	103-Z9002 121-Z9065 121-Z9065 921-1114 121-Z9065 121-Z9065 121-987-03 121-987-03 HE-443-780 HE-443-698 HE-443-698 221-Z9042 221-Z9042 HE-443-46 HE-443-755 HE-443-897 HE-443-779 HE-443-877 HE-443-877 905-369 905-369 HE-443-764	

CC3 COMMODORE
MODEL VIC 20

10 PARTS LIST AND DESCRIPTION (Continued)

When ordering parts, state Model, Part Number, and Description

SEMICONDUCTORS (Select replacement for best results) (cont)

REPLACEMENT DATA									
ITEM No.	TYPE No.	MFGR. PART No.	EGG PART No.	GENERAL ELECTRIC PART No.	MOTOROLA PART No.	NTE PART No.	RCA PART No.	WORKMAN PART No.	ZENITH PART No.
UD7	MOS901460-03		ECG74LS245		SN74LS245N	NTE74LS245			HE-443-885
UD8	SN74LS245N		ECG74LS245		SN74LS245N	NTE74LS245			HE-443-885
UD9	74LS245		ECG74S133			NTE74S133			
	SN74S133N								
	74LS133								
UE1,2	MSM2114L-3RS		ECG2114			NTE2114			HE-443-764
	MPS2114		ECG2114			NTE2114			HE-443-764
UE8	SN74LS245N		ECG74LS245		SN74LS245N	NTE74LS245			HE-443-885
	74LS245		ECG74LS245		SN74LS245N	NTE74LS245			HE-443-885
UE10	MOS6502A		ECG6502			NTE6502			
	MPS6502A		ECG6502			NTE6502			
UE11,12	MOS8205P9								
	MPS2364								
UF8	SN74LS245N		ECG74LS245		SN74LS245N	NTE74LS245			HE-443-885
	74LS245		ECG74LS245		SN74LS245N	NTE74LS245			HE-443-885

* Lead configuration may vary from original.

WIRING DATA

General-use Unshielded Hook-up Wire Use BELDEN No. 8529 (Solid) Available in 13 Colors
8522 (Stranded) Available in 13 Colors

PARTS LIST AND DESCRIPTION (Continued)

When ordering parts, state Model, Part Number, and Description

ELECTROLYTIC CAPACITORS

ITEM No.	RATING	MFGR. PART No.
C4	2.2 1%	
C5	.47 3%	
C6	.47 3%	
C7	2.2 1%	
C11	1 50V 20%	

ITEM No.	RATING	MFGR. PART No.
C15	10 16V 20%	
C17	10 16V 20%	
C33	100 16V 20%	
C39	2200 16V 20%	
C42	10 16V 20%	

CAPACITORS

ITEM No.	RATING	MFGR. PART No.
C1	.1 50V	
C2	.1 50V	
C8	.1 50V	
C9	.01 50V	
C10	.1 50V	
C12	.1 50V	
C13	220 50V 5%	
C16	.1 50V	
C18	.1 50V	
C20	.001 50V	
C21	.001 50V	
C22	.1 50V	
C23	.1 50V	
C24	.1 50V	
C25	.1 50V	
C26	.1 50V	
C27	.1 50V	
C28	.1 50V	
C29	.1 50V	

ITEM No.	RATING	MFGR. PART No.
C30	.1 50V	
C31	.22 25V	
C32	.22 25V	
C34	.22 25V	
C35	.22 100V 10%	
C36	.22 100V 10%	
C37	.1 50V	
C38	.1 50V	
C40	.1 50V	
C41	.1 50V	
C43	.01 50V	
C44	.1 50V	
C45	.1 50V	
C46	.1 50V	
C47	.1 50V	
C48	Trimmer 10-90pF	
C49	.1 50V	
C50	15 50V	
C51	.1 50V	

COMMODORE
MODEL VIC 20

CONTROLS (All wattages 1/2 watt, or less, unless listed)

ITEM NO.	FUNCTION	RESISTANCE	MFGR. PART NO.	NOTES
R10	Video Level	1000		

COILS (RF-IF)

ITEM No.	FUNCTION	MFGR. PART No.
L1	RF Choke	
L2	RF Choke	

ITEM No.	FUNCTION	MFGR. PART No.
L4	AC Filter	

PRELIMINARY SERVICE CHECKS

This data provides the user with a time-saving service tool which is designed for quick isolation and repair of computer malfunctions.

Check all interconnecting cables for good connection and correct hook-up before making service checks.

Disconnect all peripherals except the monitor from the computer to eliminate possible external malfunctions. However, problems involving the interaction between computer and a peripheral will require the connection of the device for voltage and logic readings.

Replacement or repair of the keyboard, main board, RF Modulator, or components may be necessary after the malfunction has been isolated.

GENERAL OPERATING INSTRUCTIONS

POWER UP

When the computer is turned On, it will come up ready to program in Commodore Basic.

See "Cassette Operation" for instructions on loading and saving programs.

To run a program, type RUN and press the RETURN key.

To stop a program press the RUN/STOP key.

Press the RUN/STOP key and RESTORE key at the same time to stop the program and reset the computer to the start condition, without losing the program.

CASSETTE OPERATION

Plug a Datassette cassette recorder into the six pin edge connector on the rear of the computer. Note: A regular cassette tape recorder will not work on the VIC 20.

To load a program, type LOAD, press the RETURN key and follow the instructions displayed on the Monitor screen.

To save a program, type SAVE, press the RETURN key and follow the instructions displayed on the screen.

SAMS™ Howard W. Sams & Co., Inc.
4300 West 62nd Street, P.O. Box 7092, Indianapolis, Indiana 46206 U.S.A.

The listing of any available replacement part herein does not constitute in any case a recommendation, warranty or guaranty by Howard W. Sams & Co., Inc., as to the quality and suitability of such replacement part. The numbers of these parts have been compiled from information furnished to Howard W. Sams & Co., Inc., by the manufacturers of the particular type of replacement part listed.

Reproduction or use, without express permission, of editorial or pictorial content, in any manner, is prohibited. No patent liability is assumed with respect to the use of the information contained herein.

© 1984 Howard W. Sams & Co., Inc.

4300 West 62nd Street, P.O. Box 7092, Indianapolis, Indiana 46206 U.S.A.

Printed in U.S. of America. 84CF14909

DATE 5-84



COMPUTERFACTS-OF-THE-MONTH SET NO. CF2 FOLDER CC3

PRELIMINARY SERVICE CHECKS (Continued)

SERVICE CHECKS

SEE INTERCONNECTING DIAGRAM, PLACEMENT CHART, AND PHOTOS TO MATCH THE NUMBER IN THE CIRCLES WITH THOSE IN THE FOLLOWING DATA FOR SERVICE CHECKS TO BE PERFORMED.

① RF MODULATOR CHECK

- Turn On computer and verify that the power indicator LED is lit. Note: If the power indicator is not lit, see "Power Supply Check" section.
- Verify that the channel select switch is set for the same channel as the monitor, channel 3 or 4.
- Verify that the antenna switch is in the Computer position.
- Check for bad connections, and improper hookup at the monitor and at the computer.
- If the computer still does not come up when turned On, check the RF Modulator (M2) by substitution.

② POWER SUPPLY CHECK

- Connect Power Supply (M1) to 120VAC. Check for 10.38VAC between pins 6 and 7 and 5VDC across pins 2 and 3 of the power connector (P7). If the voltages are incorrect, or not present, replace the power supply.

③ MAIN BOARD

- Check Fuse F1T1A.
- Check Power Switch with an ohmmeter.
- Check for 12.81V at Capacitor C39.
- Check for 4.99V at Coil L2.

- Computer does not power up when turned On. Check for pulses on pins 26 thru 33 of the Micro-processor IC (UE10). If the pulses are not present, check IC UE10 by substitution.
- No video (dark screen) or sound. Check the Graphics and Sound Generator ROM IC (UB7) by substitution.
- Screen comes up with black flashing squares appearing instead of characters. Check the Character Generator ROM IC (UD7) by substitution.
- Screen displays only the blue border and no information. Check ROM IC (UE11) by substitution.
- Screen display is snow only. Check ROM IC (UE12) by substitution.
- Keyboard does not operate, or the computer will not save or load a program to or from cassette. Check Interface IC (UAB1) by substitution.
- RUN/STOP and RESTORE keys do not operate when pushed at the same time, or the cassette motor won't run to save or load a program. Check Interface IC (UAB3) by substitution.

④ KEYBOARD

Substitute the keyboard or locate the bad key and clean the contacts with switch cleaner.

TEST EQUIPMENT AND TOOLS

TEST EQUIPMENT

Digital Volt/Ohm Meter
Logic Probe

TOOLS

Phillips Screwdriver
Small Screwdriver
Soldering Iron
Switch Cleaner

REPLACEMENT PARTS

COMMODORE VIC 20 POWER SUPPLY
COMMODORE VIC 20 RF MODULE
COMMODORE VIC 20 SWITCH BLOCK

IC	TYPE NO.
UAB1	MPS6522
UAB3	MPS6522
UB7	MPS6560
UD7	901460-03
UE10	MPS6502A
UE11	8250P9
UE12	8250P9

PRELIMINARY SERVICE CHECKS (Continued)

DISASSEMBLY INSTRUCTIONS

CABINET REMOVAL

Remove Phillips screws 1, 2 and 3 from the cabinet bottom. Carefully lift the cabinet top up and back. The keyboard is attached to the cabinet top. Unplug the keyboard and LED power plugs and remove cabinet top. See Figure 1.

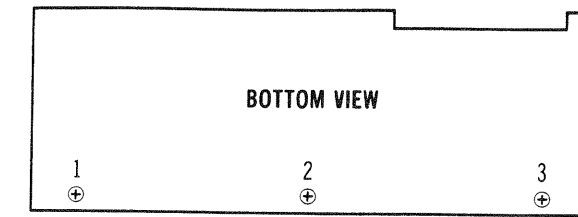

Figure 1

MAIN BOARD REMOVAL

Remove Phillips screws 1 thru 7 and lift the Main Board out of the cabinet bottom. To remove the shield, remove Phillips screws 8, 9 and 10 and unsolder the shield at points A thru G. See Figure 2.

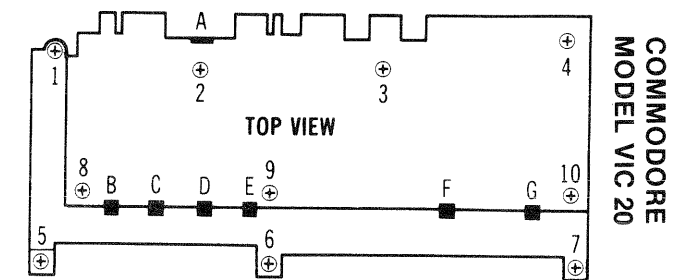

Figure 2

KEYBOARD REMOVAL

To remove the keyboard from the cabinet top, remove Phillips screws 1 thru 8 and lift the keyboard out of the cabinet. See Figure 3.

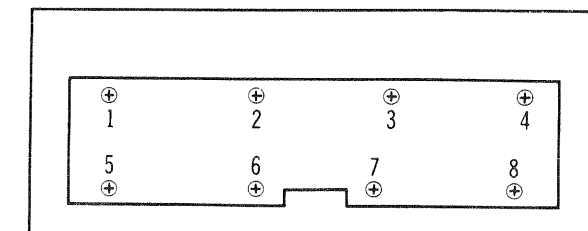
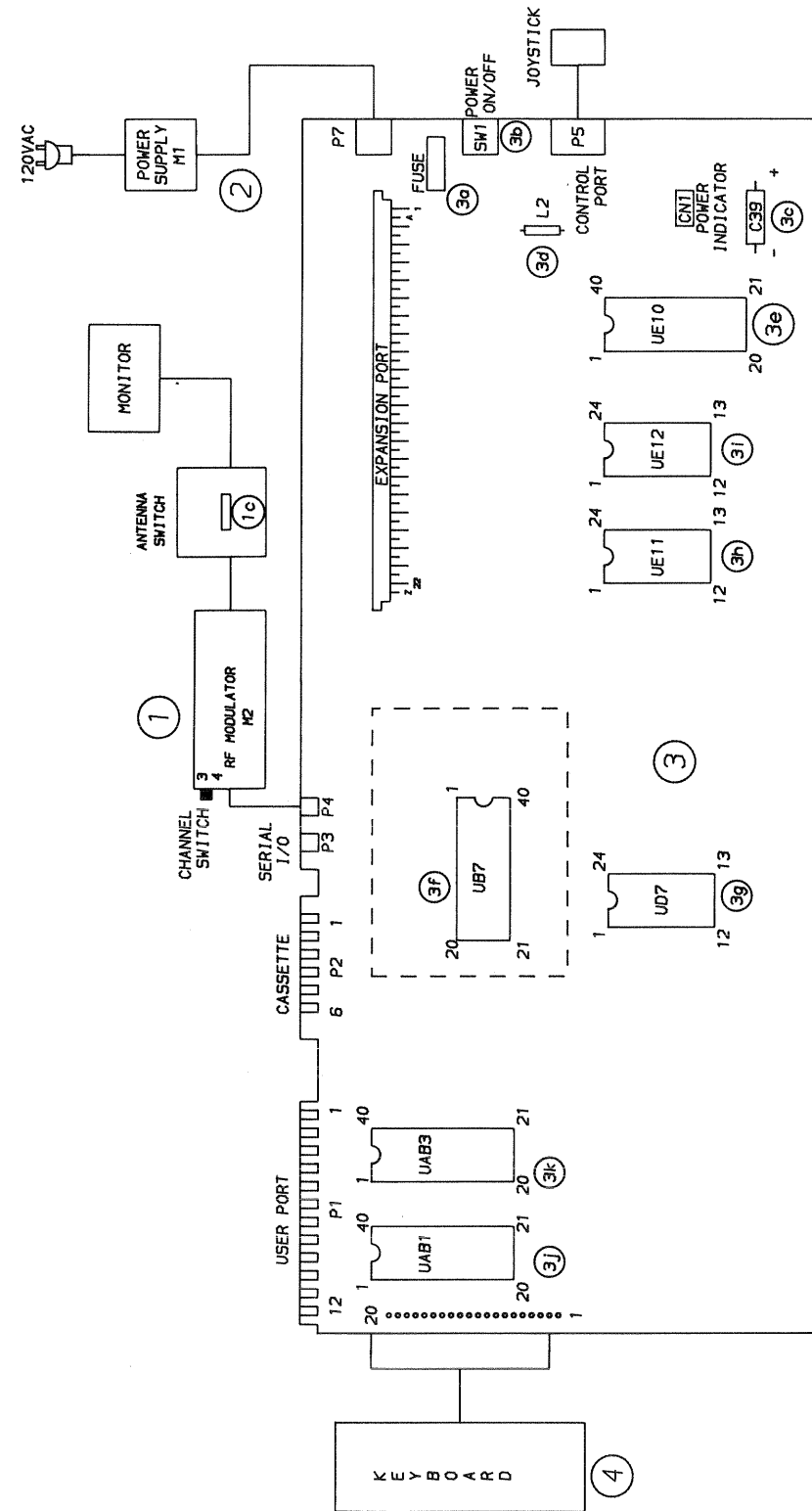
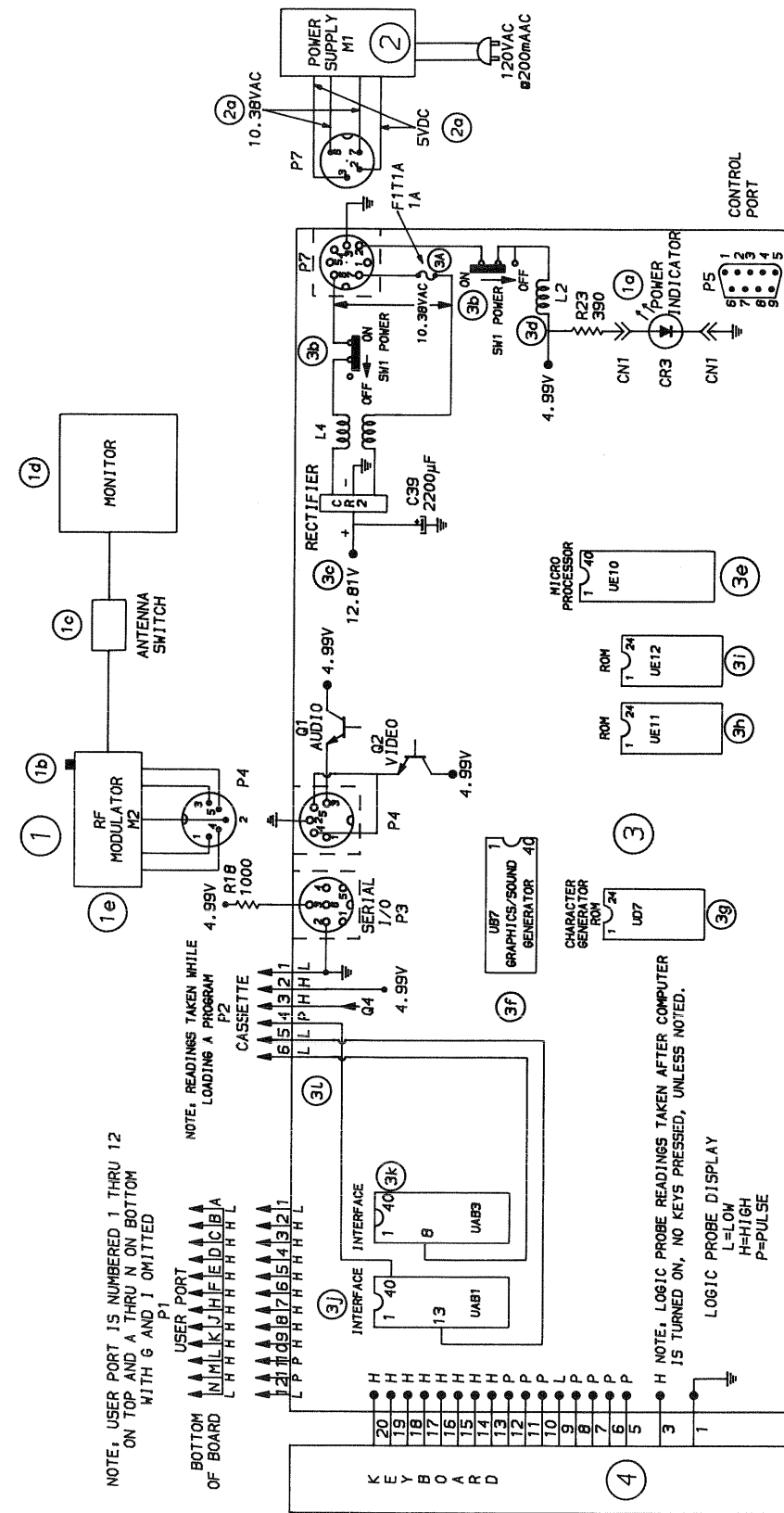

Figure 3

PRELIMINARY SERVICE CHECKS (Continued)



PRELIMINARY SERVICE CHECKS (Continued)



CC3 COMMODORE MODEL VIC 20

PRELIMINARY SERVICE CHECKS (Continued)

PRELIMINARY SERVICE CHECKS (Continued)

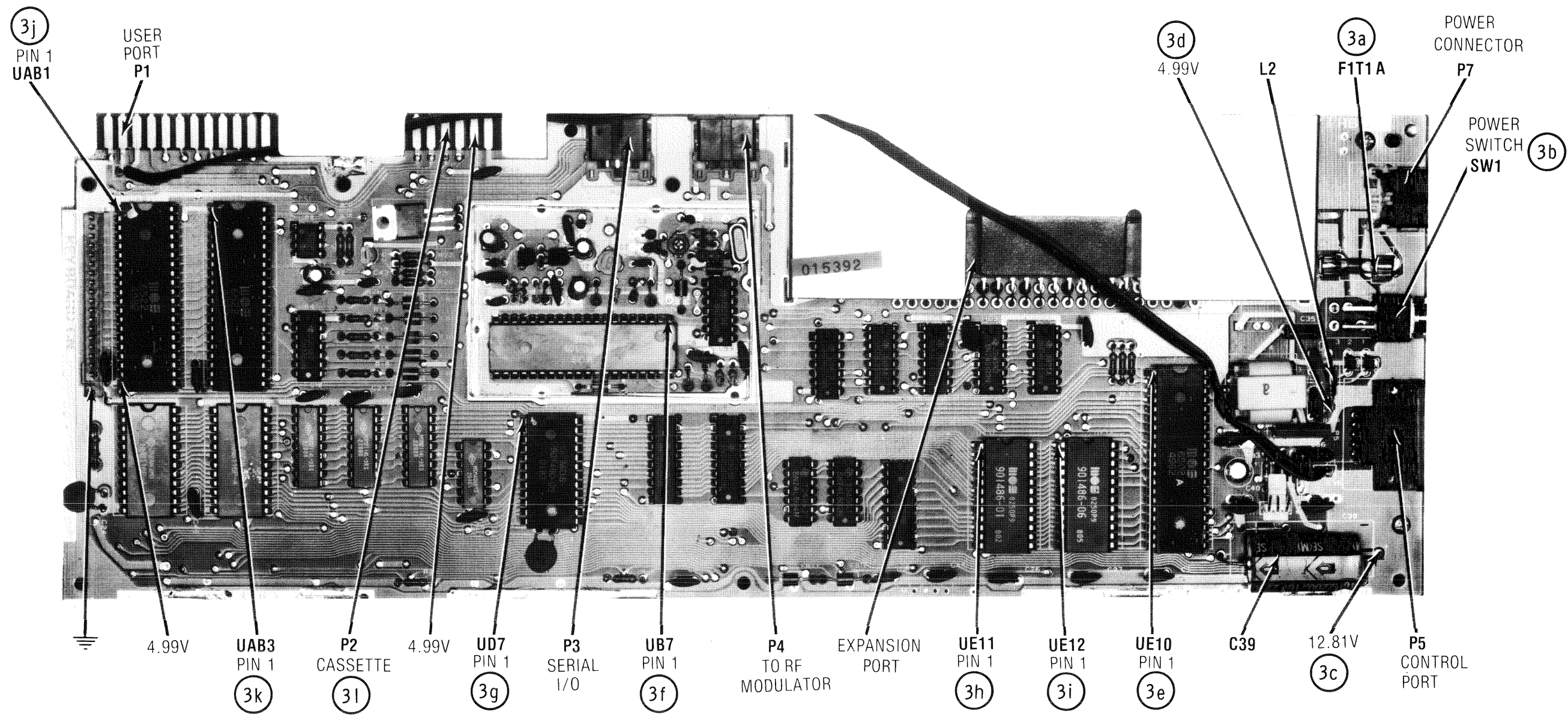

COMMODORE
MODEL VIC 20