

GENERAL OPERATING INSTRUCTIONS

POWER UP

When the computer is turned On, it will come up ready to program in Commodore Basic. See "Cassette Operation" and "Disk Operation" sections for instructions on loading and saving programs. To run a program after it is loaded, type RUN and press the RETURN key. To stop a program, press the RUN/STOP key. Pressing the RUN/STOP key and RESTORE key at the same time will stop the program and reset the computer to the start condition, without losing the program.

CASSETTE OPERATION

Plug a Datasette cassette recorder onto the six pin edge connector at the rear of the computer. Note: A regular tape recorder will not work on the Commodore 64. To load a pro-

gram, type LOAD, press the RETURN key and follow the instructions displayed on the monitor screen. To save a program, type SAVE, press the RETURN key and follow the instructions displayed on the screen.

DISK OPERATION

Connect Disk Drive unit to the Serial I/O Port (CN4) located at the rear of the computer. Carefully insert the disk so that the label on the disk is facing up and the notch on the disk is on the left side. Once the disk is inserted, close the protective gate by pushing down on the gate lever. To load a program from the disk, type LOAD "PROGRAM NAME", 8. Press the RETURN key and follow the instructions displayed on the monitor. To SAVE a program, type SAVE "PROGRAM NAME", 8 and press the RETURN key. NOTE: 8 is the code for the disk.

SAFETY PRECAUTIONS

1. Use an isolation transformer for servicing.
2. Maintain AC line voltage at rated input.
3. Remove AC power from the computer before servicing or installing electrostatically sensitive devices. Examples of typical ES devices are integrated circuits and semiconductor "chip" components.
4. Use extreme caution when handling the printed circuit boards. Some semiconductor devices can be damaged easily by static electricity. Drain off any electrostatic charge on your body by touching a known earth ground. Wear a commercially available discharging wrist strap device. This should be removed prior to applying power to the unit under test.
5. Use a grounded-tip, low voltage soldering iron.
6. Use an isolation (times 10) probe on scope.
7. Do not remove or install boards, floppy disk drives, printers, or other peripherals with computer AC power On.
8. Do not use freon-propelled sprays. These can generate electrical charges sufficient to damage semiconductor devices.
9. This computer is equipped with a grounded three-pronged AC plug. This plug must fit into a grounded AC power outlet. Do not defeat the AC plug safety feature.
10. Periodically examine the AC power cord for damaged or cracked insulation.
11. The computer cabinet is equipped with vents to prevent heat build-up. Never block, cover, or obstruct these vents.
12. Instructions should be given, especially to children, that objects should not be dropped or pushed into the vents of the cabinet. This could cause shock or equipment damage.
13. Never expose the computer to water. If exposed to water, turn the unit off. Do not place the computer near possible water sources.
14. Never leave the computer unattended or plugged into the AC outlet for long periods of time. Remove AC plug from AC outlet during lightning storms.
15. Do not allow anything to rest on AC power cord.
16. Unplug AC power cord from outlet before cleaning computer.
17. Never use liquids or aerosols directly on the computer. Spray on cloth and then apply to the computer cabinet. Make sure the computer is disconnected from the AC power line.



COMMODORE
MODEL C64 (1984 VERSION)

CC17
MODEL C64 (1984 VERSION)
COMMODORE

PRELIMINARY SERVICE CHECKS

ENCLOSED

SAFETY PRECAUTIONS

See page 21.

INDEX

	Page		Page
Adjustment	14	Parts List	9,10,11
Block Diagram	18	Photos	4,6,15,17
Disassembly Instructions	14	Safety Precautions	21
General Operating Instructions	21	Schematics	2,3
GridTrace Location Guide	5	Schematic Notes	19
IC Pinouts and Terminal Guides	20	Test Equipment	7
Line Definitions	16	Troubleshooting	7,8
Logic Chart	12,13,14		

SAMS™ Howard W. Sams & Co.
4300 West 62nd Street, P.O. Box 7092, Indianapolis, Indiana 46206 U.S.A.

The listing of any available replacement part herein does not constitute in any case a recommendation, warranty or guaranty by Howard W. Sams & Co. as to the quality and suitability of such replacement part. The numbers of these parts have been compiled from information furnished to Howard W. Sams & Co. by the manufacturers of the particular type of replacement part listed.

Reproduction or use, without express permission, of editorial or pictorial content, in any manner, is prohibited. No patent liability is assumed with respect to the use of the information contained herein.
© 1986 Howard W. Sams & Co.
4300 West 62nd Street, P.O. Box 7092, Indianapolis, Indiana 46206 U.S.A.
Printed in U.S. of America. 86CC14983 DATE 9-86

SCHEMATIC NOTES

- Circuitry not used in some versions.
- - - Circuitry used in some versions.
- ⊙ See parts list.
- ⊕ Ground

Item numbers in rectangles appear in the alignment/adjustment instructions.

Supply voltage maintained as shown at input.
Voltages measured with digital meter.

Voltages and Waveforms taken with computer turned On, no keys pressed, unless otherwise noted.

Waveforms taken with triggered scope and Sweep/Time switch in Calibrate position, scope input set for DC coupling on 0 reference voltage waveforms. Switch to AC input to view waveforms after DC reference is measured when necessary. Each waveform is 9 cm. width with DC reference voltage given at the bottom line of each waveform.

Time in μ sec. per cm, given with p-p reading at the end of each waveform.

Terminal identification may not be found on unit.
Resistors are $\frac{1}{2}W$ or less, 5% unless noted.

Value in () used in some versions.

NOTE: Logic probe readings taken with computer turned On, no keys pressed, unless otherwise noted.

Logic Probe Display

L = Low

H = High

P = Pulse

* = Open (No lights On)

- (1) Probe indicates P when any key is pressed.
- (2) Probe indicates P when keys 1, 3, 5, 7, 9, +, INST DEL are pressed.
- (3) Probe indicates P when keys ←, W, R, Y, I, P, ↵, RETURN are pressed.
- (4) Probe indicates P when keys CTRL, A, D, G, J, L,], CRSR are pressed.
- (5) Probe indicates P when keys 2, 4, 6, 8, 0, -, CLR/HOME, F7 are pressed.
- (6) Probe indicates P when keys Z, C, B, M, >, SHIFT (R), SPACE BAR, F1 are pressed.
- (7) Probe indicates P when keys S, F, H, K, [, =, ⌘, F3 are pressed.
- (8) Probe indicates P when keys Q, E, T, U, O, @, ↑, F5 are pressed.
- (9) Probe indicates P when keys RUN/STOP, SHIFT LOCK, SHIFT (L), X, V, N, <, ↓, CRSR ↓ are pressed.
- (10) Probe indicates P during LOAD and SAVE.
- (11) Probe indicates L during SAVE.
- (12) Probe indicates L when PLAY or RECORD key is pressed.
- (13) Video Interface Chip and Sound Interface Device should have separate ground returns.
- (14) C107 is 50pF when used with U19 (MOS6567 versions R4, R4T2).
C107 or C203 is 220pF when used with U19 (MOS6569 version R1).

IC PINOUTS & TERMINAL GUIDES

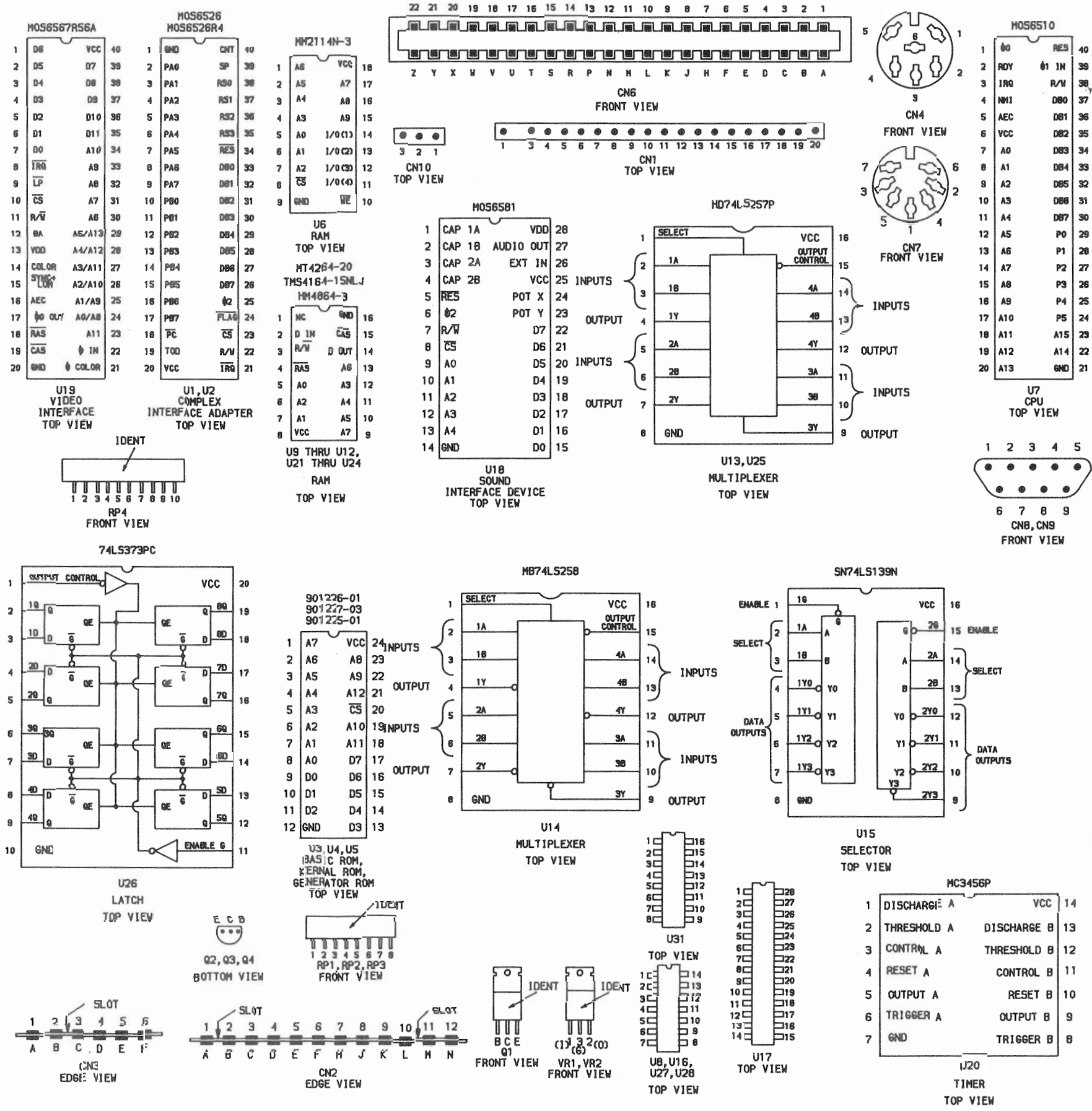

POWER UP

When the computer is turned On, program in Commodore Basic. See and "Disk Operation" sections for and saving programs. To run a pro type RUN and press the RETURN key press the RUN/STOP key. Pressing RESTORE key at the same time will reset the computer to the start cond program.

CASSETTE OPERATION

Plug a Datasette cassette recorder connector at the rear of the compute recorder will not work on the Commc

1. Use an isolation transformer for
2. Maintain AC line voltage at rat
3. Remove AC power from the con typical ES devices are integrat
4. Use extreme caution when hanl by static electricity. Drain of commercially available dischar under test.
5. Use a grounded-tip, low voltag
6. Use an isolation (times 10) pro
7. Do not remove or install board
8. Do not use freon-propelled sp devices.
9. This computer is equipped with outlet. Do not defeat the AC p
10. Periodically examine the AC p
11. The computer cabinet is equip
12. Instructions should be given, e: the cabinet. This could cause
13. Never expose the computer to ble water sources.
14. Never leave the computer unatt AC outlet during lightning stor
15. Do not allow anything to rest c
16. Unplug AC power cord from ou
17. Never use liquids or aerosols c Make sure the computer is disc

THIS WAVEFORM TAKEN AT PINS 2 THRU 9 OF U1



KEYBOARD

CABLING HEAVY LINES REDUCE USE OF MULTIPLE LINES

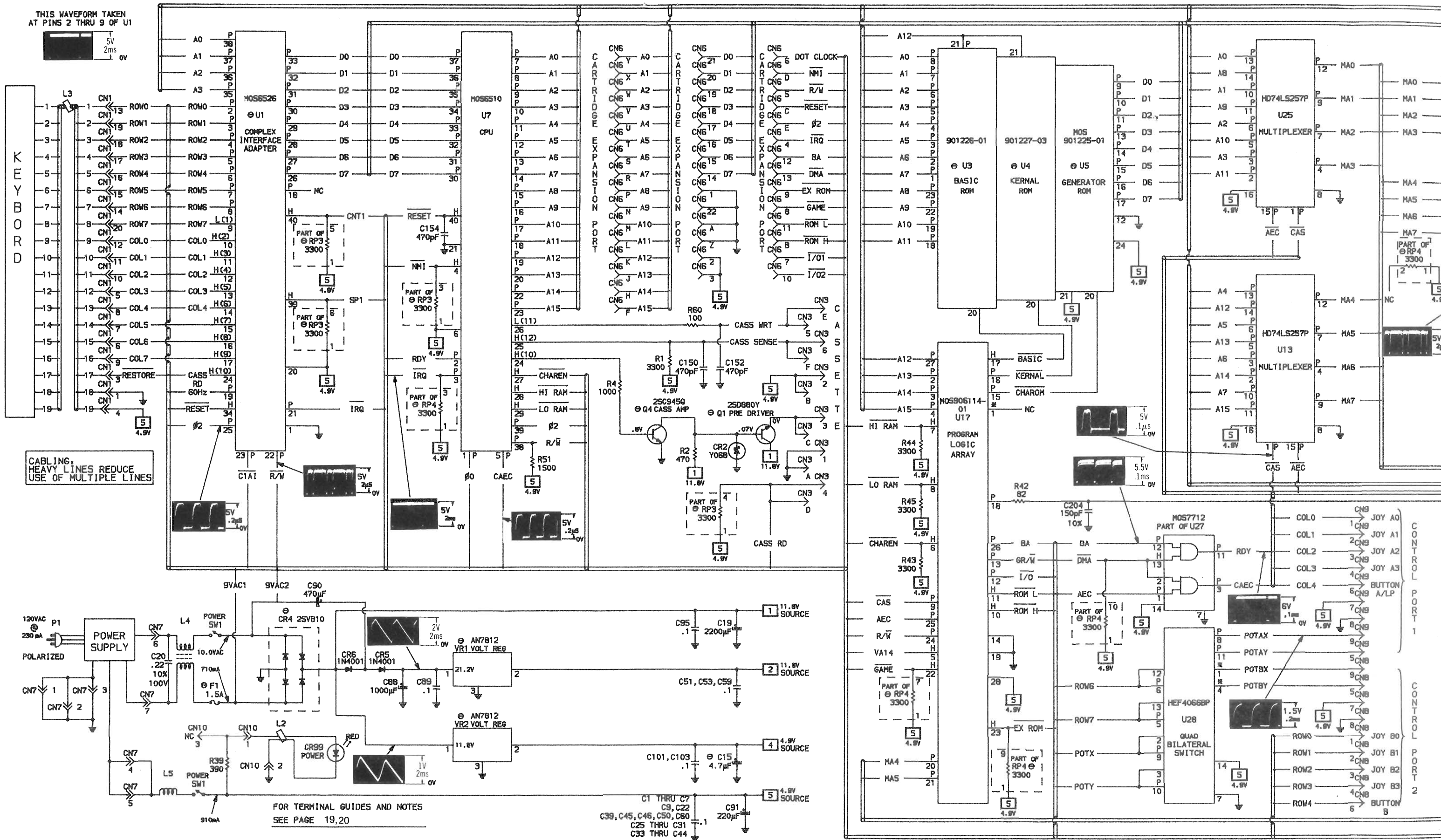

FOR TERMINAL GUIDES AND NOTES SEE PAGE 19,20

C1 THRU C7
C9, C22
C39, C45, C46, C50, C60
C25 THRU C31
C33 THRU C44
C91 220μF

A PHOTOFAC STANDARD NOTATION SCHEMATIC WITH CIRCUITRACE

© Howard W. Sams & Co. 1986

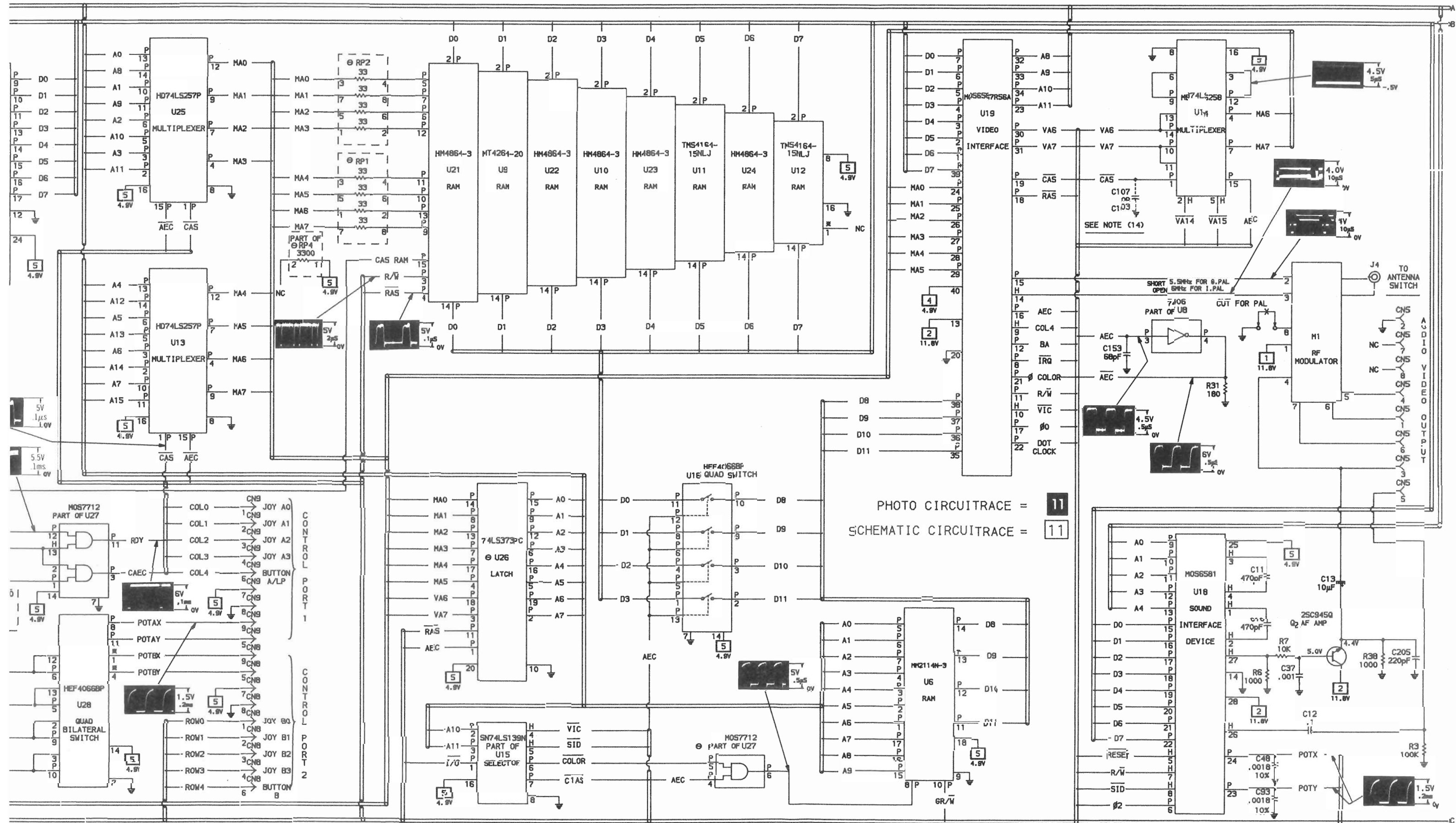

COMMODORE
MODEL C64 (1984 VERSION)

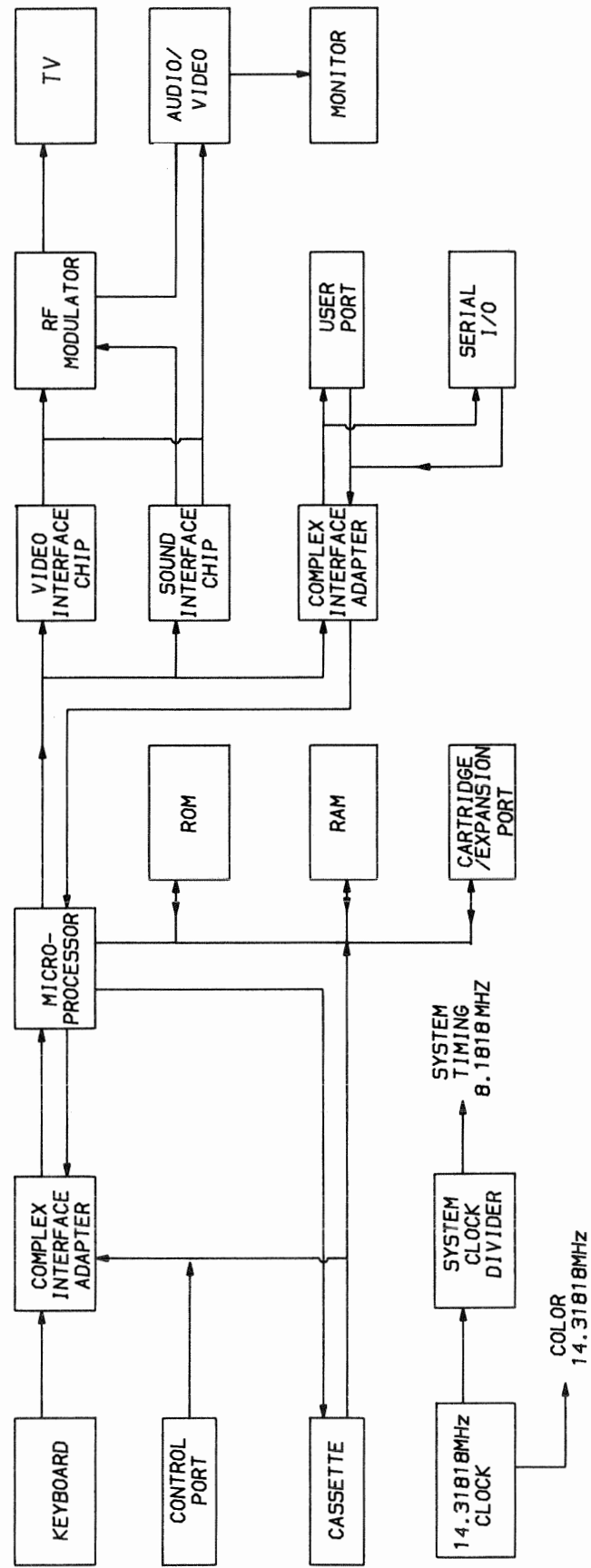

BLOCK DIAGRAM

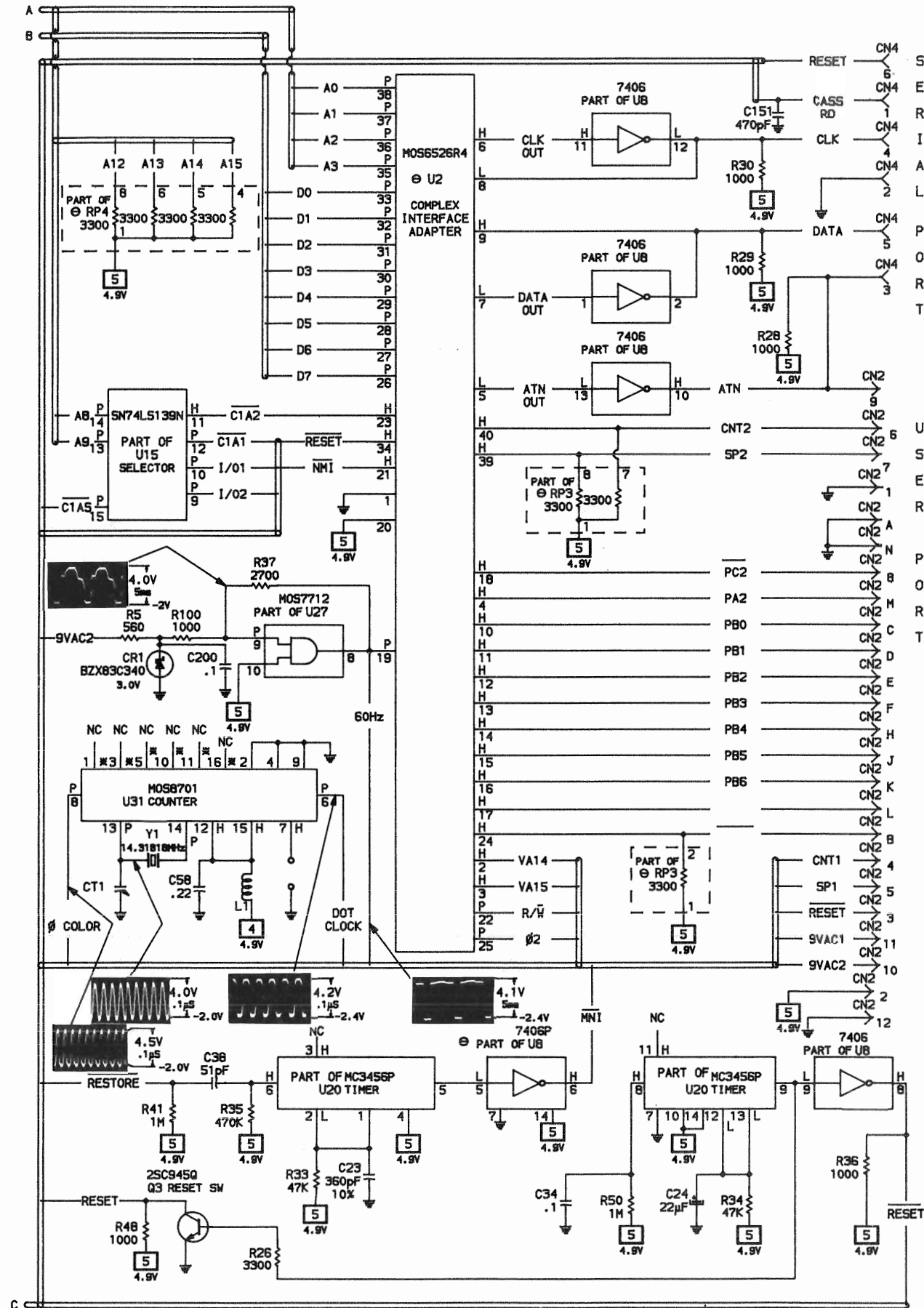

A PHOTOFACIT STANDARD NOTATION SCHEMATIC

WITH CIRCUITRACE

CC17 COMMODORE
MODEL C64 (1984 VERSION)

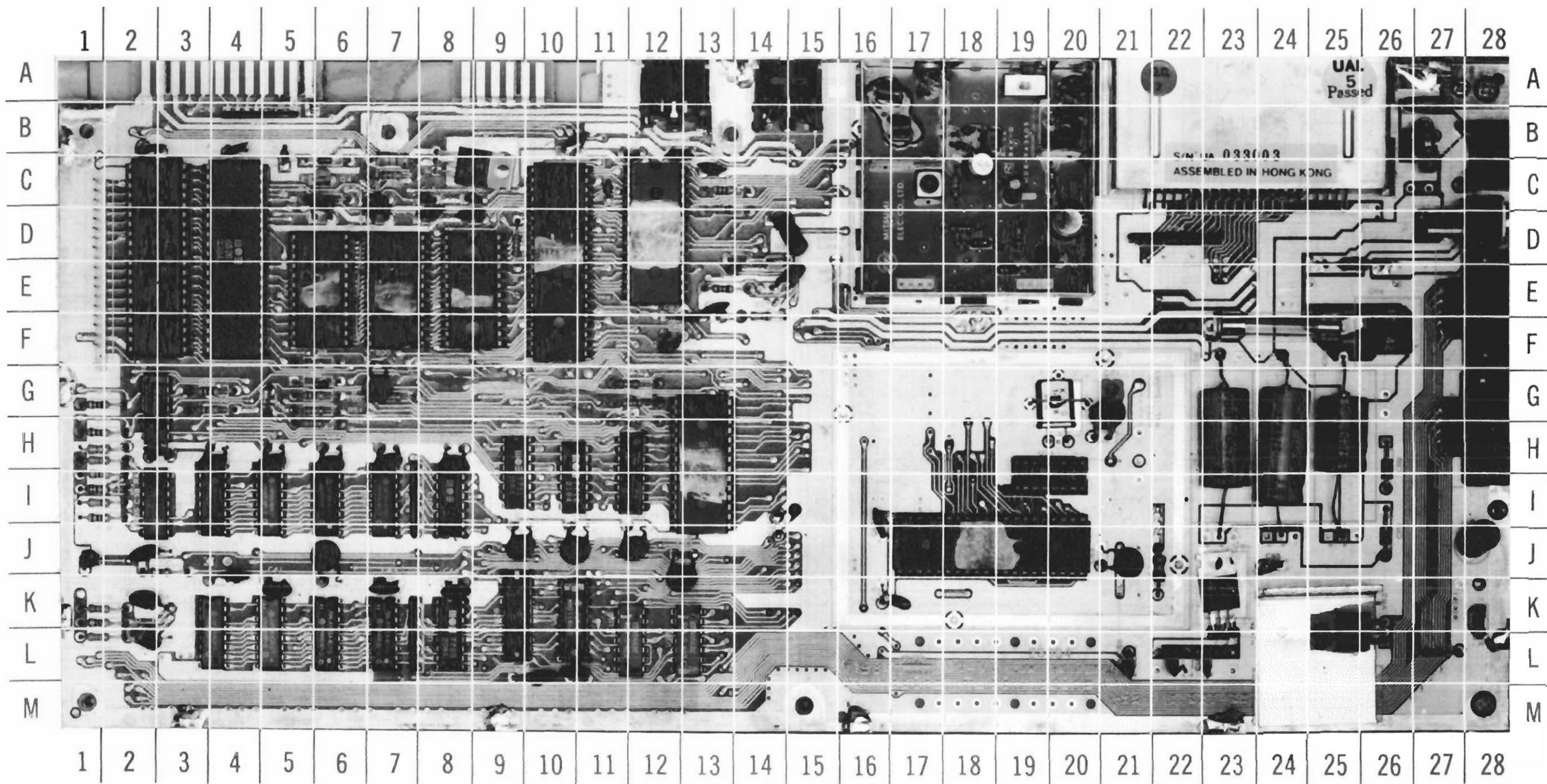

COMMODORE
MODEL C64 (1984 VERSION)

LINE DEFINITIONS

A0-A15	Address Lines	JOYA0-A3	Control Port 1 Joystick Connections
AEC	Address Enable Control	JOYB0-B3	Control Port 2 Joystick Connections
ATN	Attention	KERNAL	Kernal ROM Control Line
BA	Bus Available	LO RAM	Basic ROM Control Line
BASIC	Basic Interpreter Line	LP	Light Pen
BUTTON A/LP	Control Port A Firebutton /Light Pen Connection	MA0-MA7	Multiplex Address Lines
BUTTON B	Control Port B Firebutton Connection	NMI	Non-Maskable Interrupt
CAS	Column Address Strobe	PA0-PA7	User Port I/O Lines
CAS RAM	Column Address Strobe RAM	PB0-PB7	User Port I/O Lines
CASS RD	Cassette Read	PC2	User Port I/O Line
CASS SENSE	Cassette Sensor	PLA	Program Logic Array
CASS WRT	Cassette Write	POTAX	Port 1 Potentiometer X
CHAREN	Character Generator ROM Control Line	POTAY	Port 1 Potentiometer Y
CHAROM	Character Generator ROM Control Line	POTBX	Port 2 Potentiometer X
CIA	Complex Interface Adapter	POTBY	Port 2 Potentiometer Y
CIAS	Complex Interface Adapter Select	POTX,Y	Potentiometer X,Y
CLK	Clock	R/W	Read/Write
CNT	Counter	RAS	Row Address Strobe
COL0-COL7	Column Address Lines	RDY	Ready
COLOR	System Color	RESET	Reset Computer
CS	Chip Select	RESTORE	Pointer Reset to First Data Constant
D0-D7	Data Lines	ROM L	Active Low Decoded RAM/ROM Block Line
DATA	Serial Bus Data Line	ROM H	Buffered Decoded RAM/ROM Block Line
DMA	Direct Memory Access	ROW0-ROW7	Row Address Lines
DOT CLOCK	System Timing	SID	Sound Interface Device
EX ROM	External ROM	SP1,2	Serial Port 1,2
FLAG2	PC Data Transfer Control	VA6,7,14,15	Video Address Lines
GAME	Game I/O Line	VIC	Video Interface Chip
GR/W	Graphics Read/Write	Ø COLOR	Phase Color
HI RAM	Kernal ROM Control Line	Ø 0	Phase 0
I/O	Input/Output	Ø 2	Phase Two
IRQ	Interrupt Request	9 VAC 1,2	.60Hz Supply
		60Hz	Time of Day Clock Sync

GridTrace LOCATION GUIDE

C1	D-8	CR6	H-26	U28	L-13
C2	B-2	CT1	G-21	U31	H-20
C3	B-4	F1	F-24	VR1	K-23
C4	C-6	J4	A-17	VR2	K-25
C5	C-7	L1	J-22	Y1	G-20
C6	D-8	L4	B-27		
C7	L-10	L5	D-28		
C9	B-10	M1	C-18		
C10	B-12	Q1	C-9		
C11	C-11	Q2	D-14		
C12	E-13	Q3	J-1		
C13	D-14	Q4	C-6		
C15	K-17	R1	D-9		
C19	H-24	R2	C-7		
C20	A-21	R3	E-14		
C22	H-3	R4	C-6		
C23	H-1	R5	F-6		
C24	L-2	R6	C-13		
C25	H-4	R7	C-13		
C26	H-5	R26	K-1		
C27	H-6	R28	G-3		
C28	H-7	R29	G-1		
C29	H-8	R30	H-1		
C30	J-11	R31	J-3		
C31	J-9	R33	H-1		
C33	J-12	R34	L-1		
C34	K-2	R35	I-1		
C37	D-14	R36	G-4		
C38	I-1	R37	G-7		
C39	J-2	R38	E-13		
C40	J-4	R39	L-27		
C41	K-5	R41	I-1		
C42	J-6	R42	H-5		
C43	K-7	R43	G-12		
C44	K-8	R44	G-12		
C45	L-10	R45	G-12		
C46	J-10	R48	I-1		
C48	F-12	R50	K-1		
C50	B-12	R51	G-5		
C51	C-13	R60	C-7		
C53	J-21	R100	G-5		
C58	G-21	RP1	I-7		
C59	L-21	RP2	L-7		
C88	H-23	RP3	B-4		
C89	L-22	RP4	D-22		
C90	H-25	SW1	D-28		
C91	J-28	U1	D-3		
C93	F-13	U2	D-4		
C95	J-24	U3	E-6		
C101	I-16	U4	E-7		
C103	L-23	U5	E-9		
C150	C-9	U6	K-10		
C151	C-8	U7	D-10		
C152	C-7	U8	G-2		
C153	I-15	U9	I-4		
C154	B-5	U10	I-5		
C200	G-7	U11	I-6		
C204	G-5	U12	I-7		
C205	E-15	U13	I-8		
CN1	D-1	U14	H-12		
CN2	A-4	U15	H-9		
CN3	A-9	U16	L-12		
CN4	A-12	U17	H-13		
CN5	A-15	U18	D-12		
CN6	C-24	U19	J-18		
CN7	B-28	U20	I-2		
CN8	E-28	U21	K-4		
CN9	H-28	U22	K-5		
CN10	K-28	U23	K-6		
CR1	G-6	U24	K-7		
CR2	C-6	U25	K-8		
CR4	F-26	U26	K-9		
CR5	J-26	U27	H-10		

CC17
MODEL C64 (1984 VERSION)

COMMODORE

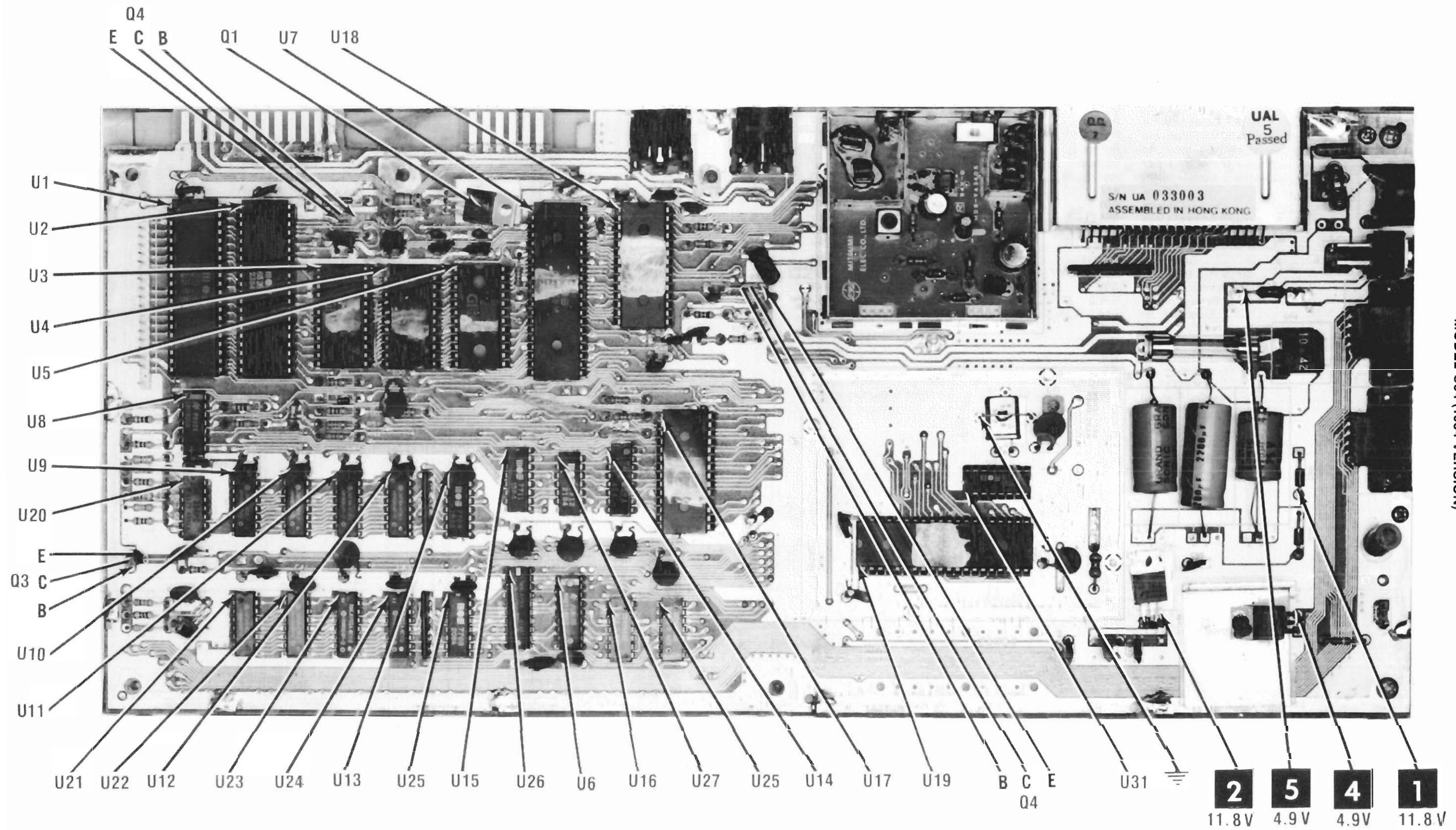

COMMODORE
MODEL C64 (1984 VERSION)

A Howard W. Sams CIRCUITRACE Photo

LOGIC CHART (Continued)

PIN NO.	IC U26	IC U27	IC U28	IC U31
1	P	P	*	*
2	P	H	P	L
3	P	P	P	*
4	P	P	*	L
5	P	P	L	H
6	P	P	P	P
7	P	L	L	H
8	P	P	P	P
9	P	P	P	L
10	L	H	P	*
11	P	P	P	*
12	P	P	P	H
13	P	H	L	P
14	P	H	H	P
15	P			H
16	P			*
17	P			
18	P			
19	P			
20	H			

ADJUSTMENT

14MHz OSCILLATOR

Connect the input of a frequency counter to pin 13 of IC (U31). Adjust CT1 for a frequency of 14.31818MHz at pin 10.

DISASSEMBLY INSTRUCTIONS

CABINET TOP REMOVAL

Remove three screws from cabinet bottom. Lift cabinet top and keyboard from cabinet bottom. Disconnect the keyboard connector and the power indicator connector from the main board.

MAIN BOARD REMOVAL

Unsolder copper strip on the top right side of the cardboard

shield and carefully fold back shield. Remove seven screws holding main board to cabinet bottom. Unsolder grounding strip at all nine places on the main board. Remove shield and main board from cabinet bottom.

KEYBOARD REMOVAL

Remove eight screws holding keyboard to cabinet top. Lift keyboard assembly from cabinet top.

TEST EQUIPMENT

Test Equipment listed by Manufacturer illustrates typical or equivalent equipment used by SAMS' Engineers to obtain measurements and is compatible with most types used by field service technicians.

TEST EQUIPMENT (COMPUTERFACTS)

Equipment Name	B & K Precision Equipment No.	Sencore Equipment No.
OSCILLOSCOPE	1570A,1590A,1596	SC61
LOGIC PROBE	DP51	
LOGIC PULSER	DP101	
DIGITAL VOM	2830	DVM37,DVM56,SC61
ANALOG VOM	277	
ISOLATION TRANSFORMER	TR110,1604,1653,1655	PR57
FREQUENCY COUNTER	1803,1805	FC71,SC61
COLOR BAR GENERATOR	1211A,1248,1251,1260	CG25,VA62
RGB GENERATOR	1260	
FUNCTION GENERATOR	3020	
HI-VOLTAGE PROBE VOM/DMM Accessory probes	HV-44	HP200
TEMPERATURE PROBE	TP-28	
CRT ANALYZER	467,470	CR70

TROUBLESHOOTING

POWER SUPPLY

The 11.8V source at anode of CR6 is missing. Check Fuse F1. If fuse has opened, check Bridge Rectifier (CR4), Capacitors C19 and C95, and Voltage Regulator (VR2) for shorts.

If fuse is good, check for 10.0VAC between Fuse F1 and Switch SW1. Check Coil L4 by measuring for 10.0VAC at pins 6 and 7 of Power Input Connector (CN7). Check Power Switch (SW1) and connections at CN7. Replace Power Supply if voltage is not correct.

The 11.76V source at pin 2 of Voltage Regulator (VR1) is missing. Check VR1, Diode CR5, Capacitors C88, C89 and C90.

The 4.91V source at positive (+) end of Capacitor C91 is missing. Check Coil L5. If Coil L5 is good, check Power Switch (SW1). Also, check the 4.91V at pin 5 of Power Input Connector (CN7). If voltage is missing, replace Power Supply.

The 4.93V source at pin 2 of Voltage Regulator (VR2) is missing. Check VR2, Capacitors C15, C101 and C103.

MICROPROCESSOR (CPU) OPERATION

Check for pulses on pins 30 thru 37, pins 7 thru 20, and pins 22 and 23 of Microprocessor IC (U7). If the Microprocessor is not working, check pin 40 of IC U7 with the logic probe, while the Computer is turned OFF and back ON again. The logic probe should read Low for about two seconds after turn-on, then read High to reset the Microprocessor.

If the logic probe reading is not correct on pin 40 of IC U7, check the voltages and components associated with the Timer IC (U20). If IC U20 is working, check for pulses on pin 3 of IC U7 and a logic High reading on pin 4 of IC U7. If the

reading is not correct on pin 3 of IC U7, check Complex Interface Adapter IC (U1) by substitution. If the reading is not correct on pin 4 of IC U7, check Complex Interface Adapter IC (U2) by substitution.

Check for Read/Write pulses on pin 38 of IC U7. Check for B+ voltage at pin 6 of Read/Write IC U7. Also, check the logic at pins 27, 28, and 29 of IC U7. Check for a clock waveform at pin 39 of IC U7.

VIDEO

No video. Check for a video waveform at pin 15 of Video Interface IC (U19). If the waveform is present, check the RF Modulator unit. If the video waveform is not present, check IC U19 by substitution.

COLOR

No color. Check for a color waveform at pin 14 of Video Interface IC (U19). If the waveform is not present, check IC U19 by substitution. If the colors are not correct, check the adjustment of the 14.31818MHz Oscillator. See "Adjustment" section.

AUDIO

No sound. Type in and run the program below. Check for an audio signal at pin 27 of Sound Interface Device IC (U18). If there is no audio signal present, check IC U18 by substitution. If an audio signal is present, check the voltages and components associated with Transistor Q8.

10 POKE 54296, 15
20 POKE 54278, 248
30 POKE 54273, 17
40 POKE 54276, 17

CC17

COMMODORE
MODEL C64 (1984 VERSION)

TROUBLESHOOTING (Continued)

KEYBOARD

Keyboard does not work. Check the waveforms at pins 2 thru 8 and pin 19 of Complex Interface Adapter IC (U1). If any of the waveforms are not present, check IC U1 by substitution. If the waveforms are present, check the operation of the keyboard by checking the logic probe readings on pins 9 thru 17 of IC U1. For readings that are not correct, check the keyboard Connector CN1, and the key switches on the keyboard for bad connections. If the keyboard still does not operate correctly, check IC U1 by substitution.

If the RESTORE key is not working, check for 0V on pin 3 of Connector CN1 when the RESTORE key is pressed. If the voltage does not drop to 0V, check for a bad connection at Connector CN1 and check the RESTORE key switch with an ohmmeter.

JOYSTICK

Joystick does not work properly. Check the voltages on the pins shown in the chart below, while the appropriate joystick position is activated. The voltages should go from about 5V to less than 0.5V. If any voltage is not correct, check the joystick switches, Connector CN9 for Port 1 and Connector CN8 for Port 2. Also check Complex Interface Adapter IC (U1) by substitution.

PORT 1			PORT 2		
IC	PIN	JOYSTICK POSITION	IC	PIN	JOYSTICK POSITION
U1	10	UP	U1	2	UP
U1	11	DOWN	U1	3	DOWN
U1	12	LEFT	U1	4	LEFT
U1	13	RIGHT	U1	5	RIGHT
U1	14	BUTTON	U1	6	BUTTON

Check the operation of the joystick by loading and running a program that uses the joystick or type into the Computer and run the following program.

```

10 P1 = PEEK (56320)
20 P2 = PEEK (56321)
30 PRINT P1, P2
40 FOR T = 1 TO 400: NEXT T
50 GOTO 10
    
```

See chart for appropriate joystick ports and positions.

JOYSTICK POSITION	PORT 1	PORT 2
CENTER	255	127
UP	254	126
DOWN	253	125
LEFT	251	123
RIGHT	247	119
BUTTON	239	111

NOTE: OTHER NUMBERS WILL APPEAR IF TWO SWITCHES ON THE JOYSTICK ARE CLOSED AT THE SAME TIME.

PADDLES

Buttons on the paddles do not work. Check the voltages on pins 12 and 13 of Complex Interface Adapter IC (U1) while using Control Port 1 and pins 4 and 5 of IC U1 while using Control Port 2. The voltage should go from 5V to 0V when the appropriate button is pressed. If the voltage does not change, check the button switches with an ohmmeter. Check Connectors CN9 (Control Port 1), and CN8 (Control Port 2) for bad connections. If the voltages check good, check IC U1 by substitution.

If the paddles do not work, check waveforms at pins 23 and 24 of Sound Interface Device IC (U18). If the waveforms are correct, check IC U18 by substitution. If the waveforms are not correct, check the paddle controls and connections with an ohmmeter. If the controls and connections are good, check Quad Bilateral Switch IC (U28) by substitution.

CASSETTE SAVE AND LOAD

Computer will not save a program to a cassette tape. Check for pulses on pin 26 of Microprocessor IC (U7) with a logic probe, while saving a program on tape. If there are no pulses, check IC U7 by substitution. If the pulses are present, check the connections at pin 5 of Connector CN3.

Computer will not load a program from a cassette tape. Check for pulses on pin 24 of Complex Interface Adapter IC (U1) with a logic probe, while loading a program from tape. If the pulses are present, check IC U1 by substitution. If the pulses are not present, check the connections at pin 4 of Connector CN3.

Datassette cassette motor will not start when the recorder is put in Play or Record mode. Check the voltage at pin 25 of IC U7. The voltage on pin 25 should drop from 4.96V to .02V when the Datassette cassette recorder is in the Play or Record mode.

If the voltage does not change, check the connection at pin 6 of Connector CN3. If the voltage is correct, check the voltage at pin 24 of IC U7. The voltage on pin 24 should drop from 2.98V to .08V when the Datassette cassette recorder is put in the Play or Record mode. If the voltage is good, check the voltages and components associated with Transistors Q1 thru Q3.

See the voltage chart below for voltages with the recorder in Play or Record mode.

	E	B	C
Q1	6.5V	6.9V	10.7V
Q4	0V	.07V	6.9V

Note: Voltages taken with Datassette cassette recorder running.

LOGIC CHART (Continued)

PIN NO.	IC U8	IC U9	IC U10	IC U11	IC U12	IC U13	IC U14	IC U15	IC U16	PIN NO.	IC U17	PIN NO.	IC U17
1	L	*	*	*	*	P	P	P	P	1	*	21	P
2	H	P	P	P	P	P	H	P	P	2	P	22	H
3	P	P	P	P	P	P	P	P	P	3	P	23	H
4	P	P	P	P	P	P	P	H	P	4	P	24	P
5	L	P	P	P	P	P	H	H	P	5	H	25	P
6	H	P	P	P	P	P	P	P	P	6	H	26	P
7	L	P	P	P	P	P	P	P	L	7	H	27	P
8	H	H	H	H	H	L	L	L	P	8	H	28	H
9	L	P	P	P	P	P	P	P	P	9	P		
10	L	P	P	P	P	P	P	P	P	10	H		
11	H	P	P	P	P	P	P	H	P	11	H		
12	H	P	P	P	P	P	P	P	P	12	P		
13	L	P	P	P	P	P	P	P	P	13	P		
14	H	P	P	P	P	P	P	P	H	14	L		
15		P	P	P	P	P	P	P		15	P		
16		L	L	L	L	H	H	H		16	P		
17										17	H		
18										18	P		
19										19	L		
20										20	P		

PIN NO.	IC U18	PIN NO.	IC U18	PIN NO.	IC U19	PIN NO.	IC U19	PIN NO.	IC U20	IC U21	IC U22	IC U23	IC U24	IC U25
1	H	21	P	1	P	21	P	1	L	*	*	*	*	P
2	H	22	P	2	P	22	P	2	L	P	P	P	P	P
3	H	23	P	3	P	23	P	3	H	P	P	P	P	P
4	H	24	P	4	P	24	P	4	H	P	P	P	P	P
5	H	25	H	5	P	25	P	5	L	P	P	P	P	P
6	P	26	H	6	P	26	P	6	H	P	P	P	P	P
7	H	27	H	7	P	27	P	7	L	P	P	P	P	P
8	H	28	H	8	P	28	P	8	H	H	H	H	H	L
9	P			9	H	29	P	9	L	P	P	P	P	P
10	P			10	H	30	P	10	H	P	P	P	P	P
11	P			11	P	31	P	11	H	P	P	P	P	P
12	P			12	P	32	P	12	L	P	P	P	P	P
13	P			13	H	33	P	13	L	P	P	P	P	P
14	L			14	H	34	P	14	H	P	P	P	P	P
15	P			15	P	35	P	15		P	P	P	P	P
16	P			16	P	36	P	16		L	L	L	L	H
17	P			17	P	37	P	17						
18	P			18	P	38	P	18						
19	P			19	P	39	P	19						
20	P			20	L	40	H	20						

COMMODORE
MODEL C64 (1984 VERSION)

LOGIC CHART

PIN NO.	IC U1	PIN NO.	IC U1	PIN NO.	IC U2	PIN NO.	IC U2	PIN NO.	IC U3	PIN NO.	IC U3
1	L	21	P	1	L	21	H	1	P	21	P
2	P	22	P	2	H	22	P	2	P	22	P
3	P	23	P	3	H	23	H	3	P	23	P
4	P	24	H(10)	4	H	24	H	4	P	24	H
5	P	25	P	5	L	25	P	5	P		
6	P	26	P	6	H	26	P	6	P		
7	P	27	P	7	L	27	P	7	P		
8	P	28	P	8	L	28	P	8	P		
9	L(1)	29	P	9	H	29	P	9	P		
10	H(2)	30	P	10	H	30	P	10	P		
11	H(3)	31	P	11	H	31	P	11	P		
12	H(4)	32	P	12	H	32	P	12	L		
13	H(5)	33	P	13	H	33	P	13	P		
14	H(6)	34	H	14	H	34	H	14	P		
15	H(7)	35	P	15	H	35	P	15	P		
16	H(8)	36	P	16	H	36	P	16	P		
17	H(9)	37	P	17	H	37	P	17	P		
18	P	38	P	18	H	38	P	18	P		
19	P	39	H	19	P	39	H	19	P		
20	H	40	H	20	H	40	H	20	H		

PIN NO.	IC U4	PIN NO.	IC U4	PIN NO.	IC U5	PIN NO.	IC U5	PIN NO.	IC U6	PIN NO.	IC U7	PIN NO.	IC U7
1	P	21	P	1	P	21	H	1	P	1	P	21	L
2	P	22	P	2	P	22	P	2	P	2	P	22	P
3	P	23	P	3	P	23	P	3	P	3	P	23	P
4	P	24	H	4	P	24	H	4	P	4	H	24	H(10)
5	P			5	P			5	P	5	P	25	H(12)
6	P			6	P			6	P	6	H	26	L(11)
7	P			7	P			7	P	7	P	27	H
8	P			8	P			8	P	8	P	28	H
9	P			9	P			9	L	9	P	29	H
10	P			10	P			10	P	10	P	30	P
11	P			11	P			11	P	11	P	31	P
12	L			12	L			12	P	12	P	32	P
13	P			13	P			13	P	13	P	33	P
14	P			14	P			14	P	14	P	34	P
15	P			15	P			15	P	15	P	35	P
16	P			16	P			16	P	16	P	36	P
17	P			17	P			17	P	17	P	37	P
18	P			18	P			18	H	18	P	38	P
19	P			19	P			19	P	19	P	39	P
20	P			20	P			20	P	20	P	40	H

- (1) Probe indicates P when any key is pressed.
- (2) Probe indicates P when keys 1, 3, 5, 7, 9, +, INST DEL are pressed.
- (3) Probe indicates P when keys ←, W, R, Y, I, P, *, RETURN are pressed.
- (4) Probe indicates P when keys CTRL, A, D, G, J, L,], CRSR are pressed.
- (5) Probe indicates P when keys 2, 4, 6, 8, 0, -, CLR/HOME, F7 are pressed.
- (6) Probe indicates P when keys Z, C, B, M, >, SHIFT (R), SPACE BAR, F1 are pressed.
- (7) Probe indicates P when keys S, F, H, K, [, =, ⌫, F3 are pressed.
- (8) Probe indicates P when keys Q, E, T, U, O, @, ↑, F5 are pressed.
- (9) Probe indicates P when keys RUN/STOP, SHIFT LOCK, SHIFT (L), X, V, N, <, ?, ↑ CRSR ↓ are pressed.
- (10) Probe indicates P during LOAD and SAVE.
- (11) Probe indicates P during SAVE.
- (12) Probe indicates L when PLAY or RECORD key is pressed.

PARTS LIST AND DESCRIPTION

When ordering parts, state Model, Part Number, and Description

SEMICONDUCTORS (Select replacement for best results)

ITEM No.	TYPE No.	MFR. PART No.	REPLACEMENT DATA				NOTES
			NTE PART No.	ECG PART No.	RCA PART No.	ZENITH PART No.	
CR1	BZ83C3V0		NTE5004A	ECG5004A	SK3A0/5004A	103-Z9009	
CR2	Y068		NTE5014A	ECG5014A	SK6A8/5014A	212-76-02	
CR4	S2VB10		NTE5313	ECG5313	SK3986/5313	121-987-03	
CR5,6	1N4001		NTE116	ECG116	SK3311	121-972*	
Q1	(2S)D880Y		NTE152	ECG152	SK3440/291		
Q2,3,4	(2S)C945Q		NTE85	ECG85	SK3124A/289A		
U1	MOS6526						
U2	MOS626R4						
U3	9464C-0839						
U4	901226-01						
	901227-03						
	26012B-840						
U5	901225-01						
	21035H-177						
U6	MM2114N-3		NTE2114	ECG2114	SK2214/2114	HE-443-764	
U7	MOS6510		NTE7406	ECG7406	SK7406	HE-443-698	
U8	7406						
U9	MT4264-20		NTE4164	ECG2164		HE-443-970	
U10	HM4864-3		NTE4164	ECG2164		HE-443-970	
U11,2	TMS4164-15NLJ		NTE4164	ECG2164		HE-443-970	
U13	HD74LS257P		NTE74LS257	ECG74LS257	SK7CT257	HE-443-802	
U14	MB74LS258		NTE74LS258	ECG74LS258	SK7CT258		
U15	SN74LS139N		NTE74LS139	ECG74LS139	SK7CT139	HE-443-822	
U16	HEF4066BP		NTE4066B	ECG4066B	SK4066B	905-369	
U17	MOS906114-01						
U18	MOS6581						
U19	MOS6567R56A						
U20	MC3456P		NTE978	ECG978	SK3689/978	221-Z9152	
U21,2,3,4	SAME AS U10						
U25	SAME AS U13						
U26	74LS373PC		NTE74LS373	ECG74LS373	SK7CT373	HE-443-867	

CC17
MODEL C64 (1984 VERSION)

COMMODORE

16 PARTS LIST AND DESCRIPTION (Continued)

When ordering parts, state Model, Part Number, and Description

SEMICONDUCTORS (Select replacement for best results)

ITEM No.	TYPE No.	MFGR. PART No.	REPLACEMENT DATA				NOTES
			NTE PART No.	ECG PART No.	RCA PART No.	ZENITH PART No.	
U27 U28 U31 VR1 VR2	M057712 SAME AS U16 M058701 uA7812UC uA7805UC		NTE966 NTE960	ECG966 ECG960	SK3592/966 SK3591/960	HE-442-674 221-Z9043	

* Lead configuration may vary from original.

WIRING DATA

Shielded Hook-up Wire Use BELDEN No. 8401 or 8421 (Single-Conductor)
 8208 (Two-Conductor)
 General-use Unshielded Hook-up Wire Use BELDEN No. 8529 (Solid) Available in 13 Colors
 8522 (Stranded) Available in 13 Colors
 300-Ohm Input Lead Use BELDEN No. 8225
 75-Ohm Input Lead Use BELDEN No. 8241

PARTS LIST AND DESCRIPTION (Continued)

When ordering parts, state Model, Part Number, and Description

ELECTROLYTIC CAPACITORS

ITEM No.	RATING	MFGR. PART No.
C15	4.7 16V	

RESISTORS (Power and Special)

ITEM No.	RATING	REPLACEMENT DATA		
		MFGR. PART No.	NTE PART No.	WORKMAN PART No.
RP1, RP2	Resistor Network (1)			
RP3 RP4	Resistor Network (2) Resistor Network (3)			

(1) Contains four (4 each) 33 ohm, 5%.
 (2) Contains seven (7 each) 3300, 5%.
 (3) Contains nine (9 each) 3300, 5%.

COILS & TRANSFORMERS

ITEM No.	FUNCTION	MFGR. PART No.	OTHER IDENTIFICATION	NOTES
L1 L4 L5	RF Choke AC Line Choke RF Choke			

FUSE DEVICES

ITEM NO.	DESCRIPTION	MFGR. PART NO.		NOTES
		DEVICE	HOLDER	
F1	1.5A @ 250V Normal Blow			

MISCELLANEOUS

ITEM No.	PART NAME	MFGR. PART No.	NOTES
CR99 L2 L3 M1 SW1 Y1	LED Ferrite Bead Ferrite Bead RF Modulator Switch Crystal Feet		Power, Red Power 14.31818MHz RUSSELL Replacement PAD-5012 (4 required)

MODEL C64 (1984 VERSION)
 COMMODORE

PRELIMINARY SERVICE CHECKS (Continued) PREVENTATIVE MAINTENANCE

ENVIRONMENT

Computers perform best in a clean, cool area that is below 80 degrees Fahrenheit and free of dust and smoke particles. Even though home Computers are not affected by cigarette smoke as much as commercial Computers are affected, it is better to maintain a smoke-free area around the Computer. Do not block cabinet vents of any of the Computer system; Computer, Monitor, Printer, or other power devices.

ELECTRICAL POWER

Variations in the line voltage can affect the Computer. Try to avoid these fluctuations by using an AC receptacle that is on a power line not used by appliances or other heavy current demand devices. A power-surge protector, power-line conditioner, or non-interruptible power supply may be needed to cure the problem. **Do not** switch power On and Off frequently.

KEYBOARD

Liquids spilled into the Keyboard can ruin it. Immediately after a spill occurs, disconnect the Computer power plug from AC power outlet. Then, if circuitry or contacts are contaminated, disassemble the Keyboard and carefully rinse the Keyboard printed circuit board with distilled water and let it dry. Use a cotton swab to clean between the keys. Use a non-abrasive contact cleaner and lint-free wipers on accessible connectors and contacts.

DISK DRIVES

Clean the read/write heads of the Disk Drives about once a month or after 100 hours usage. Use only an approved head cleaning kit.

Handle carefully to preserve proper disk head alignment. A sudden bump or jolt to the Disk Drives can knock the disk head out of alignment. If the disk drive must be transported, place an old disk in slot and close door during transport.

Store disks in their protective covers and never touch the disk surface. Observe the disk handling precautions usually found on the back of disk protective covers.

PRINTERS

Carefully vacuum the Printer regularly. Wipe surface areas clean using a light all-purpose cleaner. Do not oil the machine. The oil will collect abrasive grit and dust. The dust will act as a blanket. This can cause components to overheat and fail.

STATIC ELECTRICITY

Static electricity discharge can affect the Computer. In order to minimize the possibility, use anti-static mats, sprays, tools and materials, and maintain good humidity in the Computer environment.

MONITOR

Use an isolation transformer with any Monitor that does not come as part of the system since some Monitors use a HOT chassis (chassis connected to one side of the AC line). The face of the Monitor should never be left on for long periods of time at high brightness level except when pattern is being changed periodically. Use caution when cleaning anti-glare screens, to preserve the glare-reduction feature.

SAMS COMPUTERFACTS™

COMMODORE
MODEL C64 (1984 VERSION)

PRELIMINARY SERVICE CHECKS

This data provides the user with a time-saving service tool which is designed for quick isolation and repair of computer malfunctions.

Check all interconnecting cables for good connection and correct hook-up before making service checks.

Disconnect all peripherals except the monitor from the computer to eliminate possible external malfunctions. However, problems involving the interaction between computer and a peripheral will require the connection of the device for voltage and logic readings.

Replacement or repair of the keyboard, main board, RF Modulator, or components may be necessary after the malfunction has been isolated.

TEST EQUIPMENT AND TOOLS

TEST EQUIPMENT

Digital Volt/Ohm Meter
Logic Probe

TOOLS

Small Screwdriver
Phillips Screwdriver
Soldering Iron
Desoldering Equipment
Switch Cleaner (non-spray type)

REPLACEMENT PARTS

Power Supply for Commodore 64
Fuse 1A 250V 3AG
Bridge Rectifier CR4, Diodes CR5, CR6

IC	TYPE NO.	IC	TYPE NO.
U1	6526	U18	6581
U2	6526	U19	6567R8
U4	901227-03	VR1	AN7812
U7	6510CBM	VR2	AN7805
U17	906114-01		

COMMODORE
MODEL C64 (1984 VERSION)
CC17

CC17
COMMODORE
MODEL C64 (1984 VERSION)

SAMS™ Howard W. Sams & Co.
4300 West 62nd Street, P.O. Box 7092, Indianapolis, Indiana 46206 U.S.A.

The listing of any available replacement part herein does not constitute in any case a recommendation, warranty or guaranty by Howard W. Sams & Co. as to the quality and suitability of such replacement part. The numbers of these parts have been compiled from information furnished to Howard W. Sams & Co. by the manufacturers of the particular type of replacement part listed.

Reproduction or use, without express permission, of editorial or pictorial content, in any manner, is prohibited. No patent liability is assumed with respect to the use of the information contained herein.

© 1986 Howard W. Sams & Co.
4300 West 62nd Street, P.O. Box 7092, Indianapolis, Indiana 46206 U.S.A.
Printed in U.S. of America. 86CC14983 DATE 9-86

PRELIMINARY SERVICE CHECKS (Continued)

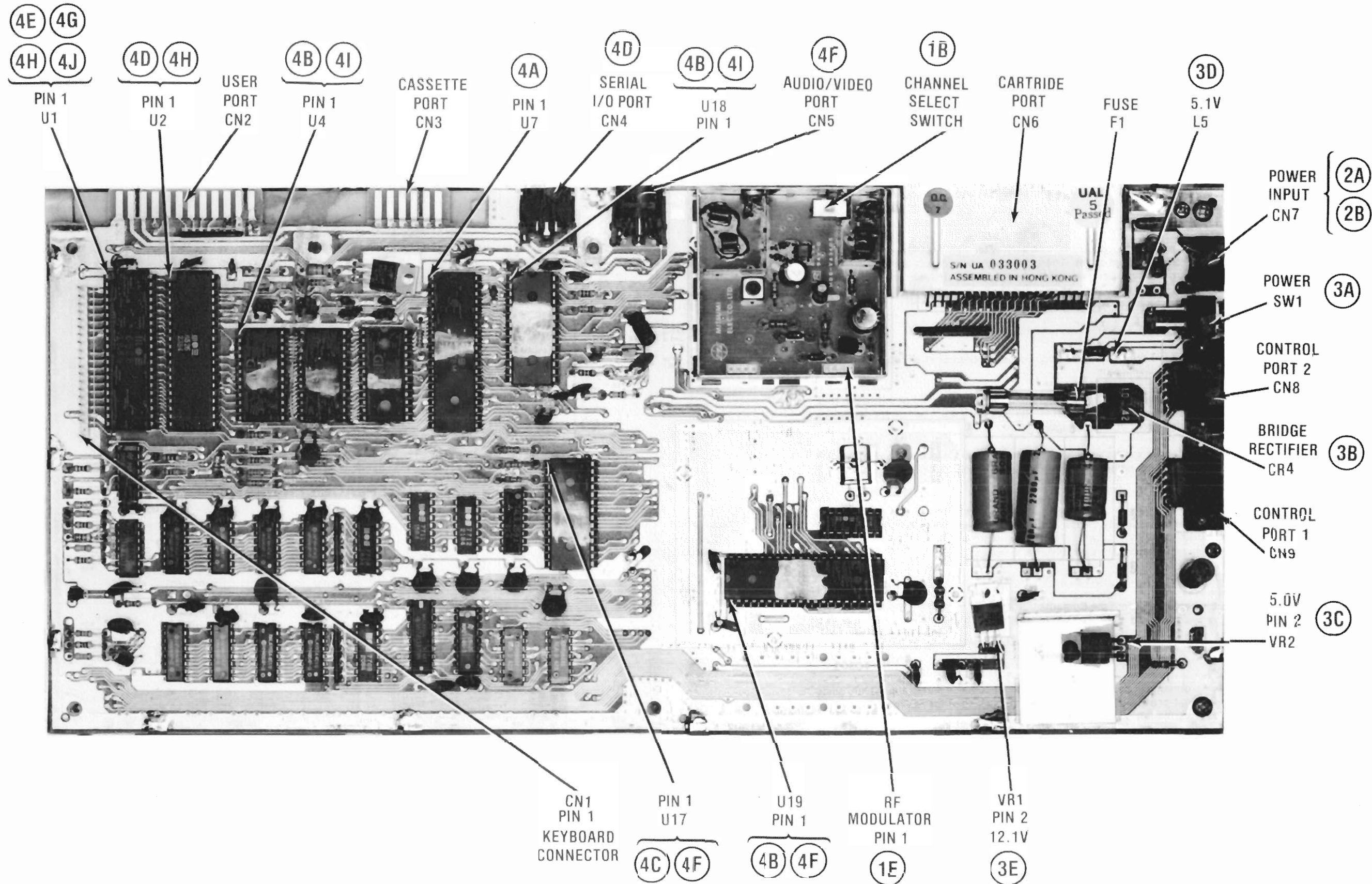

COMMODORE
MODEL C64 (1984 VERSION)

PRELIMINARY SERVICE CHECKS (Continued)

DISASSEMBLY INSTRUCTIONS

CABINET TOP REMOVAL

Remove three screws from cabinet bottom. Lift cabinet top and keyboard from cabinet bottom. Disconnect the keyboard connector and the power indicator connector from the main board.

MAIN BOARD REMOVAL

Remove the seven screws holding Main board to cabinet bottom. Remove heat sink shield from top of Main board. Unsolder grounding strip at all 11 places on Main board. Remove shield and Main board from cabinet bottom.

KEYBOARD REMOVAL

Remove eight screws holding the Keyboard to cabinet top. Lift Keyboard assembly from cabinet top.

GENERAL OPERATING INSTRUCTIONS

POWER UP

When the computer is turned On, it will come up ready to program in Commodore Basic. See "Cassette Operation" or "Disk Operation" for instructions on loading and saving programs. To run a program, type RUN and press the RETURN key. To stop a program, press the RUN/STOP key. Pressing the RUN/STOP key and RESTORE key at the same time will stop the program and reset the computer to start condition, without losing the program.

CASSETTE OPERATION

Plug a Datassette cassette recorder onto the six pin edge connector at the rear of the computer. Note: A regular tape recorder will not work on the Commodore 64. To load a program, type LOAD, press the RETURN key and follow the instructions displayed on the monitor screen. To save a program, type SAVE, press the RETURN key and follow the instructions displayed on the screen.

DISK OPERATION

Connect Disk Drive Unit to the Serial Port located at the rear of the computer. Carefully insert the disk so that the label on the disk is facing up and the notch on the disk is on the left side. Once the disk is inserted, close the protective gate by pushing down on the gate lever. To load a program from the disk, type LOAD "PROGRAM NAME", 8. Press the RETURN key and follow the instructions displayed on the monitor. To SAVE a program, type SAVE "PROGRAM NAME", 8 and press the RETURN key. NOTE: 8 is the code for the disk.

PRELIMINARY SERVICE CHECKS (Continued)

SERVICE CHECKS

MATCH THE NUMBERS ON THE INTERCONNECTING DIAGRAM AND PHOTOS WITH THE NUMBERS ON THE SERVICE CHECKS TO BE PERFORMED.

① RF MODULATOR CHECK

- (A) Turn On computer and verify the power indicator LED is lit. Note: If the power indicator LED is not lit, see the "Power Supply Check" and "Main Board (Power Check)" sections.
- (B) Verify the channel select switch is on the same channel as the monitor, channel 3 or 4.
- (C) Verify the antenna switch is in Computer position.
- (D) Check for bad connections and improper hook-up at the monitor and at the computer.
- (E) If the computer still does not come up when powered, check the voltages at the RF Modulator connection points. If the voltages are correct, substitute the RF Modulator.

② POWER SUPPLY CHECK

- (A) Connect Power Supply to 120VAC. Disconnect power connector CN7 from computer. Check for 10.90VAC across pins 6 and 7 of CN7.
- (B) Check for 5.08V across pins 2 and 4 of CN7. If the voltages are not present or are incorrect, replace the power supply.

③ MAIN BOARD (POWER CHECK)

- (A) If the power indicator LED does not light when computer is powered, check the Fuse F1 and the Power Switch (SW1).
- (B) Check for 11.77V at the Bridge Rectifier (CR4).
- (C) Check for 4.93V at pin 2 of Voltage Regulator VR2.
- (D) Check for 4.91V at Coil L5.
- (E) Check for 11.76V at pin 2 of Voltage Regulator VR1.

④ MAIN BOARD (PROCESSING)

- (A) If the power supply checks normal and the computer does not come up when powered, verify Microprocessor IC (U7) is working by checking for pulses on pins 7 thru 20, 22, 23, and 30 thru 37.
- (B) If the Microprocessor is working and the computer does not come up, check by substitution Kernal ROM IC (U4), Program Logic Array IC (U17) and Video Interface Chip IC (U19).
- (C) No audio. Check Sound Interface Device IC (U18) by substitution.
- (D) Disk Drive or Printer does not function properly. Check Complex Interface Adapter IC (U2) by substitution.
- (E) Datassette cassette does not operate. Check Complex Interface Adapter IC (U1) by substitution.
- (F) Audio/Video Port does not work. Check Sound Interface Device IC (U18), and Video Interface Chip IC (U19) by substitution.
- (G) Keyboard does not operate. Check Complex Adapter IC (U1) by substitution. Also see "Keyboard" section.
- (H) Modem does not operate. Check both Complex Interface Adapter IC's (U1 and U2) by substitution.
- (I) Cartridge Port does not work. Check by substitution Program Logic Array IC (U17) and Kernal Rom IC (U4).
- (J) Control Ports do not work. Check Complex Interface Adapter IC (U1) by substitution.

⑤ KEYBOARD

Substitute the keyboard or locate the bad key and carefully clean the key switch with switch cleaner.

CC17

COMMODORE
MODEL C64 (1984 VERSION)

PRELIMINARY SERVICE CHECKS (Continued)

